



# BAMBOO JOURNAL



IBRA ONLINE NEWSLETTER

*Year 4*

*Number 7*

*September 2011*



ITALIAN BAMBOO RODMAKERS ASSOCIATION



### *In this issue*

- Page 3*      *Editorial*  
By Marco O. Giardina
- Page 5*      *Adventures with spigot ferrules*  
By Tim Anderson
- Page 14*     *Bamboo and flies*  
By Alberto Calzolari
- Page 21*     *Mario Chiari*  
By Riccardo Baerlocher
- Page 28*     *A different approach to making bamboo ferrules*  
By Olar Ovidiu
- Page 32*     *Wood Fly Reelmaker Andrea Satto*  
By Alberto Poratelli
- Page 36*     *Argentina bamboo week*  
By Massimo Tirocchi
- Page 42*     *Images by European Gathering 2011*
- Page 47*     *Experiments with various types of sections*  
By Gabriele Gori e Marco Giardina
- Page 55*     *Discussions on "Shark Tooth" hollowing*  
By Gabriele Gori e Alberto Poratelli
- Page 66*     *Food for thought : "Waterlog Magazine"*  
By Marco Giardina

#### **Bamboo Journal n. 7 - Ottobre 2011**

Editor            Marco O. Giardina ([editor@rodmakers.it](mailto:editor@rodmakers.it))

Photos by        Alberto Poratelli, Marco O Giardina,  
Gabriele Gori, Moreno Borriero, Simone Repetti  
Tim Anderson, Olar Ovidiu, Andrea Satto,  
Massimo Tirocchi

Graphic art work and  
e creative director    Alberto Poratelli

Translation      Moreno e Doria Borriero ([info@damlin.com](mailto:info@damlin.com))

Front cover:     Arturo Pugno, master of the Valsesiana style of  
fishing, in action with a vintage bamboo rod. In the  
Sermenza stream

Photo on page 2:    Reels in briar and aluminium  
Made by Andrea Satto



8th May 2011

Harry Boyd, Special Guest at the 4th European  
Gathering which took place in Sansepolcro (Italy)



## Editorial

**T**he long wall that divides my house from the rest of the world is slowly changing the color. The thick Virginia Creeper that covers it slowly becomes reddish and soon all the leaves will have fallen.

Only the green patches of ivy will remain. They fought with the Virginia Creeper for the sun and the still free patches of wall.

It is Autumn.

The months of fishing and adventures, discoveries along rivers and torrents are over.

Now it is time to build. Building bamboo rods.

Therefore, we take out the planing form preserved from rust by the light veil of protecting oil. We put them back on the bench, clean up and luster them. We sharpen the blades and check the engine of our bevellers.

As the Poet says:

*"September, let's go. It is time to migrate.*

*Now in the land of Abruzzi my shepherds*

*Leave their stations and go toward the sea;*

*They descend to the savage Adriatic,*

*Green as the meadows in the mountains."*

Alike we migrate towards our workshops, garages, rooms in concession, that are our savage Adriatic. Dust and chips, the smell of turpentine and varnishes and glues are waiting for us. Sometimes strong, sometimes sweet. Splinters of bamboo under the nails and cuts on the hands.

What we could wish more from life.

We take out from the row bamboo culm the beauty of a strong and delicate, beautiful and unique instrument: the Bamboo Rod for fly fishing.

This issue of BJ contains some articles of undoubtedly interest on building aspects - among them all I cite the two on the ferrule - Considerations on experimentations that at this point the IBRA carrying out from some years, diaries of travel and other diaries, diaries of the spirit like the article of Alberto Calzolari.

I hope that you enjoy reading this issue and if you would like to send me comments and considerations please write down your notes at [m-o-g@iol.it](mailto:m-o-g@iol.it)

I am a little slow in replying - I am lazy - but I will reply, at my pace.

I promise!

*The Editor*

In this issue:

*"INSECTS"*

Photos by Simone Repetti



# Adventures with Spigot Ferrules

§§§

By Tim Anderson

**I**nspired by bamboo ferrules by Bjarne Fries, Robert Stroh, Philipp Sicher, and Alberto Poratelli, I decided some time ago to try, for cane rods, spigot ferrules. I am now on the sixth generation of the spigots. Each spigot has been based on carbon fiber shafts or rods, but shapes and other materials have changed. There have been carbon fiber combined with bamboo, carbon fiber, titanium, bronze and PEI plastic, and now I am making spigots from carbon-fiber rod, bronze, and more carbon fiber. The sockets for the spigots are the bamboo of the blank.

A major problem is that I keep coming up with new ideas which I like to call improvements. My rods are three or four piece (Figure 1) and the ferrules closest to the tips provide the greatest challenge.



*Figure 1. A 7' 6" three-piece rod with detail of its largest ferrule and an 8' 6" four-piece rod.*

Spigot ferrules are best known from graphite and fiberglass rods, but, in most such rods today, a larger section of the rod slides over the smaller end of another section (usually tip over butt). Most bamboo ferrules in cane rods are made this way. Spigot ferrules use a spigot inside the blank and the two rod sections can have the same size at the join.

Figure 2 shows the six successful generations (earliest on the top) of my spigot ferrules for cane rods and all are based on a thinner, carbon-fiber rod with a thicker, hexagonal stiffener at the point where the rod sections join. The hexagonal, thicker portion of my spigots maintains the alignment of the rod's flats. I first tried spigots without the stiffener; they didn't break, but hinged dramatically and I did not consider them successful!



Figure 2. The six generations of my spigot ferrules, with the first on top.

Generation one of the spigots used a carbon-fiber core surrounded by a hexagonal mantle of bamboo. The stiffener at the join tapered and was the bamboo of the blank. Generation two eliminated the bamboo mantle around the smaller part of the spigot. Generation three used tapered carbon-fiber as the stiffener. In these first three generations, the tapered shape of the stiffeners slowly wedges the ferrule open with repeated casting.

Generations four to six have stiffeners without any taper. The stiffener of generation four is titanium, of five is PEI plastic and bronze (alloy 630), and of six is woven carbon fiber and bronze (alloy 510).

Figure 3 shows the internal structure of my spigot ferrules. The spigot (male) side of the blank has the spigot permanently glued in place. I glue it in when gluing up the blank. In generations four through six, one-half of the stiffener is inside the spigot side of the blank.



*Figure 3. Internal structure of the ferrules.*

Because the spigots are partly hexagonal, at least partly hexagonal cavities need to be prepared in the blank on both sides of the joint. I use a Morgan Hand Mill and cut the cavities in generations four through six with a flat cutter, so the entire cavity is hexagonal (Figure 4). Others have used spigots without any hexagonal parts which allows drilling of the sockets after the blank is glued up. I think the hexagonal section is advantageous because it keeps a rod's flats and guides aligned.

I cut the sockets slightly oversize and, after gluing up the blank, clean them out so that the spigot slides easily into place. I then fit the joint using 5-minute epoxy, giving a perfect fit (Figure 5). For this fitting, a high-quality mold release (I use Ultra 4 Epoxy Parfilm) is necessary on the male side as is careful binding of the female side with masking tape so that it does not split during the process.

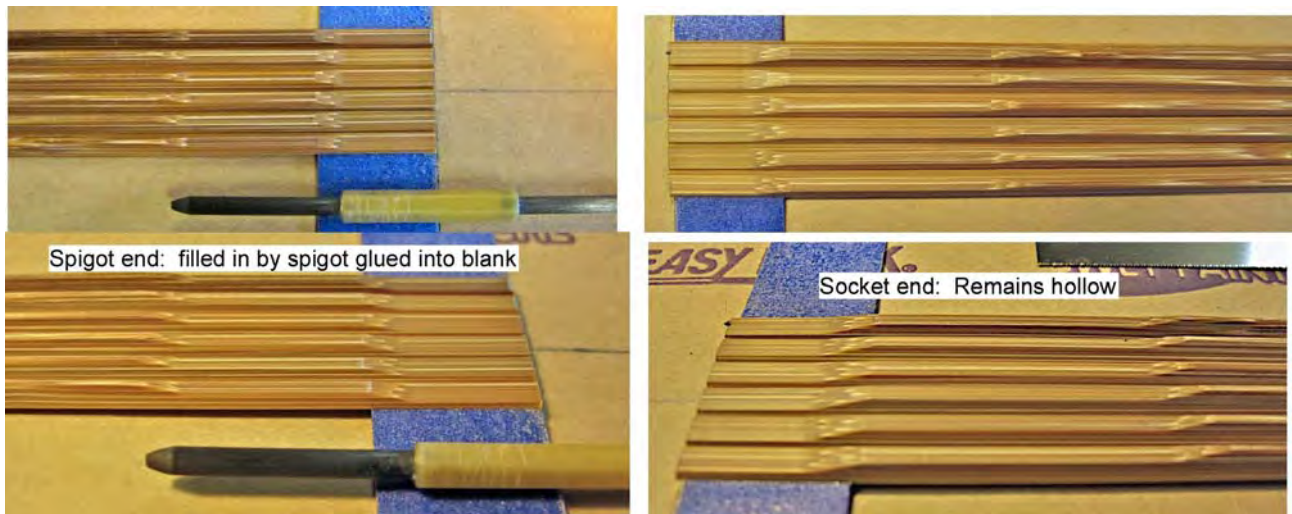

Figure 4. Details of sockets and spigots before gluing the blank.



Figure 5. Preparation for fitting spigot to socket.

I put the mixed 5-minute epoxy in the female socket, heat the socket with a heat gun so that the epoxy is very fluid, and push the male side firmly into place. After about one hour, I gently heat the socket area with a heat gun (set at about 300° F/150° C), pull the ferrule apart, and immediately push it back together. I let that sit for about 12 hours (the epoxy is now very hard) before disassembly and clean-up.

My spigots, having no taper, commonly require heating the joint again to have it come apart; slight additional fitting after the rod is complete is sometimes necessary to relieve tightness.

A friend has used, with good results, my 5-minute epoxy method on his bamboo ferrules. The male side of many bamboo ferrules has a slight taper, so subsequent assembly/disassembly is easier than for my non-tapered spigots.

Figures 6 and 7 show details of spigot generations five and six. The bronze tubes add stiffness. The flats in the central, hexagonal stiffeners of the spigots are cut after gluing. As with my blanks, I use UHU Endfest Plus 300 for gluing up and/or laminating the spigots. Three to four laminated layers of bi-axial carbon fiber sleeve (purchased from [www.solarcomposites.com](http://www.solarcomposites.com)) are necessary for the overlays making up the hexagonal parts of the generation-six spigots. I switched from bronze alloy 630 (generation five) to alloy 510 (generation six) because alloy 510 is supposed to have better resistance to frequent flexing.

Two spigots have broken, both being the smallest ones on four-piece rods. The first to break was generation four with titanium hexagonal stiffeners. The break was at the socket (female) end of the titanium, presumably because of the sharp contrast in stiffness between the titanium and the smaller, carbon-fiber center rod.



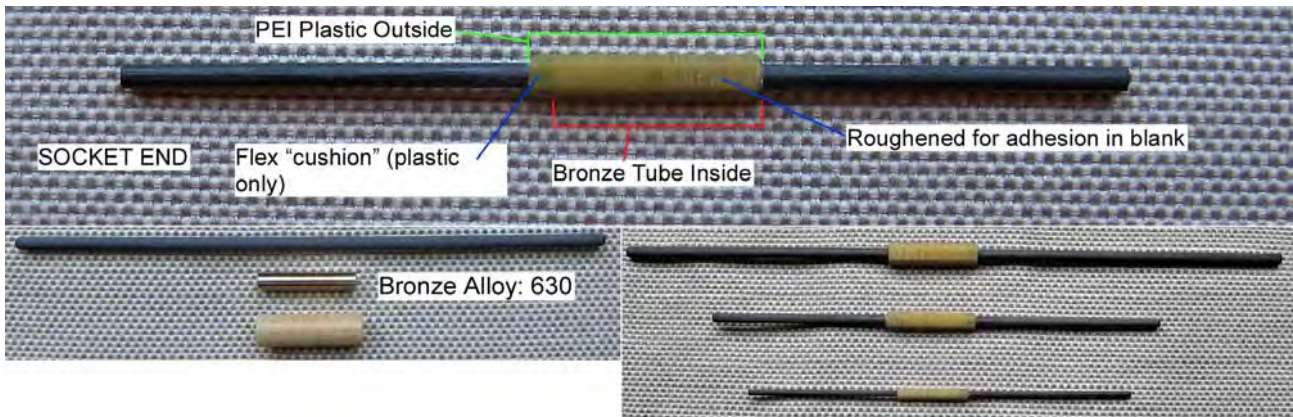
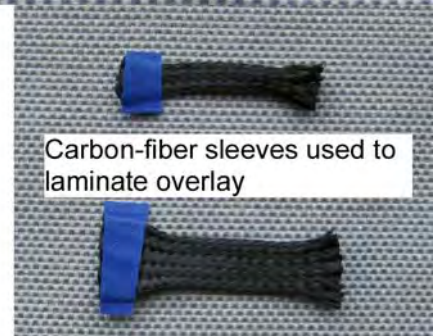

Figure 6. Spigot generation five. Glued with UHU Endfest 300; flats cut after gluing. Bronze tube is about 0.1" (2 mm) shorter than hexagonal plastic sleeve.



Figure 7. Spigot generation six. Glued and impregnated with UHU Endfest 300; flats cut after gluing. Bronze tube is one-half the length of and centered in the carbon-fiber overlay.



The second to break was generation five (again the smallest spigot) and it broke in the center through the bronze tube. I assume that I made the walls of the tube too thin and metal fatigue allowed it to break.

I originally double wrapped silk over the parts of the blank that have thinner walls to accommodate the hexagonal stiffeners; I now use a spiraled wrap of kevlar in this location. Over the top of either and extending the full length of the spigots is another, silk, wrap.

The end of the thinner, center rod of the spigot which slides into the socket is longer than that the other, glued-in end. This provides a frictional surface to hold the assembled rod together. I use beeswax to lubricate and reduce wear in the ferrules and its stick-slip nature helps to keep the ferrules from opening while casting and fishing.

Some of the advantages of spigot ferrules are very light weight, no swell required in the blank at the ferrules, and low cost. They also look nice.

Two disadvantages are that they are time consuming to make and long-term durability is unknown.

Below are two tables (one in inches and one in centimeters), for hexagonal rods, with dimensions for the various components of my sixth generation of spigot ferrules. The diameters of the carbon-fiber rod I have been able to buy are highlighted in yellow. The hexagonal stiffener sections are 1 inch (2.54 cm) long for butt and mid sections and 0.787 inches (2 cm) long for the ferrule between a middle section and the tip section. As mentioned, one-half of the stiffener is inside the spigot (male) side of the blank, so one-half is exposed for the socket (female) side.

*Tim Anderson*



*Tim and Ursula Anderson at the 2011 European Gathering in Sansepolcro*

Spigot dimensions - inch.

Taper at Ferrule Flat-to-Flat (Inches)	Carbon Fiber Rod Diameter (Inches)	Bronze Tube Outside Diameter (Inches)	Hex Section Flat-to-Flat (Inches)	Hex Section Roughing Diam. (Inches)	Minimum Female Spigot Length (Inches)	Minimum Male Spigot Length (Inches)	Minimum Total Spigot Length (Inches)	Bamboo Wall Thickness over Hex Section (Inches)
0.144	0.070	0.095	0.110	0.187	1.700	1.255	2.955	0.017
0.146	0.071	0.095	0.112	0.189	1.707	1.263	2.970	0.017
0.148	0.071	0.095	0.113	0.190	1.715	1.270	2.985	0.018
0.150	0.072	0.095	0.114	0.192	1.722	1.278	2.999	0.018
0.152	0.073	0.095	0.115	0.192	1.729	1.285	3.014	0.019
0.154	0.074	0.095	0.116	0.194	1.736	1.292	3.028	0.019
0.156	0.074	0.095	0.117	0.195	1.743	1.299	3.042	0.019
0.158	0.075	0.095	0.119	0.197	1.750	1.307	3.056	0.020
0.160	0.076	0.095	0.120	0.198	1.757	1.314	3.070	0.020
0.162	0.076	0.095	0.121	0.200	1.763	1.321	3.084	0.020
0.164	0.077	0.096	0.122	0.201	1.770	1.328	3.098	0.021
0.166	0.078	0.098	0.124	0.203	1.777	1.335	3.111	0.021
0.168	0.078	0.099	0.125	0.204	1.783	1.342	3.125	0.021
0.170	0.079	0.100	0.126	0.206	1.790	1.348	3.138	0.022
0.172	0.080	0.101	0.128	0.207	1.796	1.355	3.151	0.022
0.174	0.081	0.102	0.129	0.209	1.802	1.362	3.164	0.023
0.176	0.081	0.103	0.130	0.210	1.809	1.368	3.177	0.023
0.178	0.082	0.104	0.131	0.212	1.815	1.375	3.190	0.023
0.180	0.083	0.106	0.133	0.213	1.821	1.381	3.202	0.024
0.182	0.083	0.107	0.134	0.215	1.827	1.387	3.214	0.024
0.184	0.084	0.108	0.135	0.216	1.833	1.394	3.227	0.024
0.186	0.085	0.109	0.137	0.218	1.839	1.400	3.239	0.025
0.188	0.085	0.110	0.138	0.219	1.845	1.406	3.251	0.025
0.190	0.086	0.111	0.139	0.221	1.851	1.412	3.263	0.025
0.192	0.087	0.113	0.141	0.222	1.856	1.418	3.274	0.026
0.194	0.088	0.114	0.142	0.224	1.862	1.424	3.286	0.026
0.196	0.088	0.115	0.143	0.225	1.868	1.430	3.297	0.026
0.198	0.089	0.116	0.144	0.227	1.873	1.436	3.309	0.027
0.200	0.090	0.117	0.146	0.228	1.878	1.441	3.320	0.027
0.202	0.090	0.118	0.147	0.230	1.884	1.447	3.331	0.027
0.204	0.091	0.119	0.148	0.231	1.889	1.453	3.342	0.028
0.206	0.092	0.121	0.150	0.233	1.894	1.458	3.352	0.028
0.208	0.092	0.122	0.151	0.234	1.899	1.464	3.363	0.029
0.210	0.093	0.123	0.152	0.236	1.905	1.469	3.374	0.029
0.212	0.094	0.124	0.154	0.237	1.910	1.474	3.384	0.029
0.214	0.095	0.125	0.155	0.239	1.914	1.480	3.394	0.030
0.216	0.095	0.126	0.156	0.240	1.919	1.485	3.404	0.030
0.218	0.096	0.128	0.157	0.242	1.924	1.490	3.414	0.030
0.220	0.097	0.129	0.159	0.243	1.929	1.495	3.424	0.031
0.222	0.097	0.130	0.160	0.245	1.933	1.500	3.433	0.031
0.224	0.098	0.131	0.161	0.246	1.938	1.505	3.443	0.031
0.226	0.099	0.132	0.163	0.248	1.943	1.510	3.452	0.032
0.228	0.099	0.133	0.164	0.249	1.947	1.514	3.461	0.032
0.230	0.100	0.134	0.165	0.251	1.951	1.519	3.470	0.032
0.232	0.101	0.136	0.167	0.252	1.956	1.524	3.479	0.033
0.234	0.102	0.137	0.168	0.254	1.960	1.528	3.488	0.033
0.236	0.102	0.138	0.169	0.255	1.964	1.533	3.497	0.033
0.238	0.103	0.139	0.170	0.257	1.968	1.537	3.505	0.034
0.240	0.104	0.140	0.172	0.258	1.972	1.542	3.514	0.034
0.242	0.104	0.141	0.173	0.260	1.976	1.546	3.522	0.034
0.244	0.105	0.143	0.174	0.261	1.980	1.550	3.530	0.035
0.246	0.106	0.144	0.176	0.263	1.984	1.554	3.538	0.035
0.248	0.106	0.145	0.177	0.264	1.988	1.558	3.546	0.036
0.250	0.107	0.146	0.178	0.266	1.991	1.562	3.553	0.036
0.252	0.108	0.147	0.179	0.267	1.995	1.566	3.561	0.036
0.254	0.109	0.148	0.181	0.269	1.998	1.570	3.568	0.037
0.256	0.109	0.150	0.182	0.270	2.002	1.574	3.576	0.037
0.258	0.110	0.151	0.183	0.272	2.005	1.578	3.583	0.037
0.260	0.111	0.152	0.185	0.273	2.008	1.581	3.590	0.038
0.262	0.111	0.153	0.186	0.275	2.012	1.585	3.597	0.038
0.264	0.112	0.154	0.187	0.276	2.015	1.588	3.603	0.038
0.266	0.113	0.155	0.189	0.278	2.018	1.592	3.610	0.039
0.268	0.113	0.156	0.190	0.279	2.021	1.595	3.616	0.039
0.270	0.114	0.158	0.191	0.281	2.024	1.598	3.622	0.039
0.272	0.115	0.159	0.192	0.282	2.027	1.602	3.629	0.040
0.274	0.116	0.160	0.194	0.284	2.030	1.605	3.635	0.040
0.276	0.116	0.161	0.195	0.285	2.032	1.608	3.641	0.040
0.278	0.117	0.162	0.196	0.287	2.035	1.611	3.646	0.041
0.280	0.118	0.163	0.198	0.288	2.038	1.614	3.652	0.041
0.282	0.118	0.165	0.199	0.290	2.040	1.617	3.657	0.042
0.284	0.119	0.166	0.200	0.291	2.043	1.620	3.663	0.042
0.286	0.120	0.167	0.202	0.293	2.045	1.623	3.668	0.042
0.288	0.120	0.168	0.203	0.294	2.047	1.625	3.673	0.043
0.290	0.121	0.169	0.204	0.296	2.050	1.628	3.678	0.043
0.292	0.122	0.170	0.205	0.297	2.052	1.630	3.682	0.043
0.294	0.123	0.171	0.207	0.299	2.054	1.633	3.687	0.044
0.296	0.123	0.173	0.208	0.300	2.056	1.635	3.691	0.044
0.298	0.124	0.174	0.209	0.302	2.058	1.638	3.696	0.044
0.300	0.125	0.175	0.211	0.303	2.060	1.640	3.700	0.045

Spigot dimensions - mm.

Taper at Ferrule Flat-to-Flat (mm)	Carbon Fiber Rod Diameter (mm)	Bronze Tube Outside Diameter (mm)	Hex Section Flat-to-Flat (mm)	Hex Section Roughing Diam. (mm)	Minimum Female Spigot Length (mm)	Minimum Male Spigot Length (mm)	Minimum Total Spigot Length (mm)	Bamboo Wall Thickness over Hex Section (mm)
3.66	1.78	2.41	2.79	4.75	43.18	31.88	75.06	0.43
3.71	1.80	2.41	2.84	4.81	43.37	32.07	75.44	0.43
3.76	1.81	2.41	2.87	4.84	43.55	32.26	75.81	0.44
3.81	1.83	2.41	2.90	4.87	43.73	32.45	76.18	0.46
3.86	1.85	2.41	2.91	4.89	43.91	32.64	76.55	0.47
3.91	1.87	2.41	2.94	4.92	44.09	32.82	76.92	0.48
3.96	1.88	2.41	2.98	4.96	44.27	33.01	77.28	0.49
4.01	1.90	2.41	3.01	5.00	44.44	33.19	77.63	0.50
4.06	1.92	2.41	3.04	5.04	44.62	33.37	77.99	0.51
4.11	1.94	2.42	3.08	5.08	44.79	33.55	78.34	0.52
4.17	1.96	2.45	3.11	5.11	44.96	33.73	78.69	0.53
4.22	1.97	2.48	3.14	5.15	45.13	33.90	79.03	0.54
4.27	1.99	2.51	3.18	5.19	45.29	34.07	79.37	0.55
4.32	2.01	2.54	3.21	5.23	45.46	34.25	79.70	0.55
4.37	2.03	2.57	3.24	5.27	45.62	34.42	80.04	0.56
4.42	2.04	2.59	3.27	5.30	45.78	34.58	80.37	0.57
4.47	2.06	2.62	3.31	5.34	45.94	34.75	80.69	0.58
4.52	2.08	2.65	3.34	5.38	46.10	34.92	81.01	0.59
4.57	2.10	2.68	3.37	5.42	46.25	35.08	81.33	0.60
4.62	2.12	2.71	3.41	5.46	46.41	35.24	81.65	0.61
4.67	2.13	2.74	3.44	5.49	46.56	35.40	81.96	0.62
4.72	2.15	2.77	3.47	5.53	46.71	35.56	82.27	0.63
4.78	2.17	2.80	3.50	5.57	46.86	35.71	82.57	0.64
4.83	2.19	2.83	3.54	5.61	47.01	35.87	82.87	0.64
4.88	2.20	2.86	3.57	5.65	47.15	36.02	83.17	0.65
4.93	2.22	2.89	3.60	5.68	47.29	36.17	83.46	0.66
4.98	2.24	2.92	3.64	5.72	47.44	36.32	83.75	0.67
5.03	2.26	2.95	3.67	5.76	47.58	36.47	84.04	0.68
5.08	2.28	2.98	3.70	5.80	47.71	36.61	84.32	0.69
5.13	2.29	3.01	3.74	5.84	47.85	36.76	84.60	0.70
5.18	2.31	3.03	3.77	5.88	47.98	36.90	84.88	0.71
5.23	2.33	3.06	3.80	5.91	48.12	37.04	85.15	0.72
5.28	2.35	3.09	3.83	5.95	48.25	37.18	85.42	0.72
5.33	2.36	3.12	3.87	5.99	48.37	37.31	85.69	0.73
5.38	2.38	3.15	3.90	6.03	48.50	37.45	85.95	0.74
5.44	2.40	3.18	3.93	6.07	48.63	37.58	86.21	0.75
5.49	2.42	3.21	3.97	6.10	48.75	37.71	86.46	0.76
5.54	2.44	3.24	4.00	6.14	48.87	37.84	86.71	0.77
5.59	2.45	3.27	4.03	6.18	48.99	37.97	86.96	0.78
5.64	2.47	3.30	4.06	6.22	49.11	38.10	87.21	0.79
5.69	2.49	3.33	4.10	6.26	49.23	38.22	87.45	0.80
5.74	2.51	3.36	4.13	6.29	49.34	38.34	87.69	0.80
5.79	2.52	3.39	4.16	6.33	49.45	38.46	87.92	0.81
5.84	2.54	3.42	4.20	6.37	49.57	38.58	88.15	0.82
5.89	2.56	3.45	4.23	6.41	49.67	38.70	88.38	0.83
5.94	2.58	3.47	4.26	6.45	49.78	38.82	88.60	0.84
5.99	2.60	3.50	4.30	6.48	49.89	38.93	88.82	0.85
6.05	2.61	3.53	4.33	6.52	49.99	39.04	89.03	0.86
6.10	2.63	3.56	4.36	6.56	50.09	39.15	89.25	0.87
6.15	2.65	3.59	4.39	6.60	50.19	39.26	89.46	0.88
6.20	2.67	3.62	4.43	6.64	50.29	39.37	89.66	0.89
6.25	2.68	3.65	4.46	6.67	50.39	39.48	89.86	0.89
6.30	2.70	3.68	4.49	6.71	50.48	39.58	90.06	0.90
6.35	2.72	3.71	4.53	6.75	50.58	39.68	90.26	0.91
6.40	2.74	3.74	4.56	6.79	50.67	39.78	90.45	0.92
6.45	2.76	3.77	4.59	6.83	50.76	39.88	90.64	0.93
6.50	2.77	3.80	4.63	6.86	50.85	39.98	90.82	0.94
6.55	2.79	3.83	4.66	6.90	50.93	40.07	91.00	0.95
6.60	2.81	3.86	4.69	6.94	51.02	40.16	91.18	0.96
6.65	2.83	3.89	4.72	6.98	51.10	40.25	91.35	0.97
6.71	2.84	3.91	4.76	7.02	51.18	40.34	91.52	0.97
6.76	2.86	3.94	4.79	7.05	51.26	40.43	91.69	0.98
6.81	2.88	3.97	4.82	7.09	51.33	40.52	91.85	0.99
6.86	2.90	4.00	4.86	7.13	51.41	40.60	92.01	1.00
6.91	2.92	4.03	4.89	7.17	51.48	40.68	92.17	1.01
6.96	2.93	4.06	4.92	7.21	51.55	40.77	92.32	1.02
7.01	2.95	4.09	4.95	7.25	51.62	40.84	92.47	1.03
7.06	2.97	4.12	4.99	7.28	51.69	40.92	92.61	1.04
7.11	2.99	4.15	5.02	7.32	51.76	41.00	92.76	1.05
7.16	3.00	4.18	5.05	7.36	51.82	41.07	92.89	1.05
7.21	3.02	4.21	5.09	7.40	51.89	41.14	93.03	1.06
7.26	3.04	4.24	5.12	7.44	51.95	41.21	93.16	1.07
7.32	3.06	4.27	5.15	7.47	52.01	41.28	93.29	1.08
7.37	3.08	4.30	5.19	7.51	52.06	41.35	93.41	1.09
7.42	3.09	4.33	5.22	7.55	52.12	41.41	93.53	1.10
7.47	3.11	4.35	5.25	7.59	52.17	41.48	93.65	1.11
7.52	3.13	4.38	5.28	7.63	52.23	41.54	93.76	1.12
7.57	3.15	4.41	5.32	7.66	52.28	41.60	93.87	1.13
7.62	3.18	4.44	5.35	7.70	52.32	41.66	93.98	1.13



## *Bamboo and flies*

SSS

By Alberto Calzolari



The reasons that push a modern fly fisherman to fish with a bamboo rod are many and almost always very personal. Bamboo is not chosen because of fashion trends, only in rare cases, but to achieve that awareness of emotions that this material gives when it is assembled into a bamboo rod. Bamboo could have been a starting point - as it was for many years prior to synthetic materials - or it can be the final stage of the evolution of a fly fisherman; the stage where he starts to appreciate the subtle facets of this art that we usually call sport. The phase of maturity, the research for the most difficult fish as identified by Ed Hewitt

in his famous classification of the three phases of the fisherman in which the attention is drawn further from the number and the size, to concentrate on pure enjoyment of a certain action with the best equipment one can afford. For the record the first two phases are referred to the fisherman who tries to catch as many fish as possible; the second one is to catch the biggest fish. These are phases in which the fisherman is still in his nymph stage and that he still hasn't "hatched" into the real comprehension and appreciation of the true essence. There seems to be a similarity between the stages of a mayfly and the phases of a fly fisherman.

The insect also lives for years under water in its nymph shroud, hidden among the rocks with the only objective to eat and survive. Then one day, governed by who knows which impulse, it feels the need to free itself of its shuck and to go into another dimension – the one of light and air. For a brief lapse of time these subimagos (duns) fly is if Flying were the only reason for being. A further impulse pushes them to shred another shuck and to culminate their destiny in the magic of reproduction. Their flight and the final apotheosis of the copulation are the apex of their lives.

In truth, the final stage of the elegant mayflies leads to a rapid death after copulation, without even smoking a cigarette after the embrace. In this a fly fisherman is still different and is able to enjoy the embrace without passing on to a better life in the next few hours! Speaking of embraces, I cannot but think about an entertaining phrase by Arnold Gingrich, fly fisherman, founder of the magazine Esquire in 1933 and author of numerous books on fly fishing: "...fly fishing is the most fun you can have standing up ....".

The pleasure that derives from using high quality rods and reels which are good for the eye and which also perform well technically mixes perfectly with the essence of fly fishing. As Hewitt used to say, few have the privilege to reach this maturation that is very much tied to the time spent on the river, to the knowledge and experiences which are accumulated. It is like the light at the end of a tunnel; in order to see it you need to go through it. Naturally this does not mean that to appreciate a bamboo rod, you necessarily need to reach a venerable age. Just like a beard that doesn't make you a philosopher, age is not synonymous with wisdom – at least not always. So you can (you should) approach bamboo from the very first moments spent on the river. Well this may be the panacea that cures the sick part of our sport.

The fact is that if we decide to embrace wood and repudiate synthetic, we will do this pushed in many cases by an inexplicable impulse – a mix of the research for new flavours, the need for different rhythms that are so similar the nature that surrounds us and perhaps a silent call and attraction towards a natural essence. An essence that is part of the history of man – call it a grass or call it wood – alive made of cells just as the river plants, the insects the fish and the man that hold it are made of cells.



In the fisherman that is seduced by the discovery of bamboo, there will be an activation of the chemistry that will naturally lead to look and appreciate the beauty and the essence of fly fishing with a different eye. If he loves his rod, with those delicate silk wrappings, the turned ferule and the elegance of agate with the exquisite reel seats and grips, he will not be able to love the rest of the equipment that goes with his wooden rod. It is not surprising that lovers of bamboo prefer the elegance of certain reels – from the classic one to the modern ones which are based on the design of the historical ones of the past. Some of them will be attracted by silk lines, others by bags, refined fly boxes, rod tubes and reel cases in hand sewn leather.



Carrying these fishing items and watching them working in tune with nature can already be a source of satisfaction which is independent from catching fish per se, which if we want is the trigger for fly fishing but it is not the motor nor the beating heart. Even though I am not a hunter, I find some similarities in some aspects of hunting where a solitary hunter and his dog look for something, a prey, that sometimes doesn't appear. The satisfaction of the hunter, the true hunter lies in walking in nature, observing his dog working and taking his gun for a walk.

Those few times that I adventure to the small Appennine streams, I manage to get the taste of all the aspects of this type of fishing which is made more of hunting and silence and that is so different to fly fishing in rivers. I take great pleasure in sitting on a rock for a pause to reflect (and to rest I must admit), I roll a cigarette with my blend of tobacco and I try to distinguish and select the sounds of the stream, of the water, of the birds and the rustling trees.

On that rock, a bamboo rod is not a foreign body – we are Energy and life in the middle of life. We could almost camouflage and become invisible if we wanted. To be honest, I once had the sensation that I had become invisible: it all happened during a storm, a summer storm – sudden and unpredictable – one that neither your experience nor the forecasts can foresee. Those storms that always catch you without a rain jacket. It was a hot August afternoon and I was fishing upstream in a small bushy stream with a light bamboo rod, hip waders and clad in the right kind of clothes for the environment: the colour of the rocks, the trees and the green water. The storm came up suddenly, violent and loud.

I immediately thought of my grandfather's teachings – I often do it – I don't seek shelter under the trees to not get struck by lightning but my grandfather didn't teach me what to do when you are in a deep gully surrounded only by trees and bushes. Or perhaps when I was small I wasn't listening when he told me.

I decided to seek the least dangerous thing to do and I quickly took shelter in a place of the stream where the bushes almost formed a dome of branches and the violent rain was subdued of its violence. I sat down and lay down my rod at my side ("Never hold your rod in your hand", my Grandfather used to say) and I bent over in the vain attempt to protect myself from the rain and I sat still. I then heard wings flapping and a dark shadow perched near me. It was a falcon or perhaps a buzzard that had sought refuge in the place that was probably the safest (the falcon probably didn't have advice from a grandfather). For a time that seemed eternal, we sat still, wet and dripping like two baby chicks at a very unusual and unnatural distance. I could have stretched out and touch it. I remember those eyes more than anything. Eyes that looked at me but saw no danger in me. I had become invisible, part of the woods and he did not fear the woods. It was my trembling from the cold that gave me up. In a flash he flew off and preferred the rain to the company of a human being. How can you blame him.





I have always asked myself if he stayed so close to me because of my immobility and camouflage, the lack of smells covered by the rain. But more poetically, I have always preferred to think that for a brief moment, nature, the woods had accepted me as one of its creatures. I am certain that if the rod lying on the ground between me and the falcon had been a black carbon fibre one instead of bamboo, perhaps I would not have made that encounter.

But let's get back to the rock, with my bamboo rod lying on me and my second rolled cigarette. When I am in these places, I am never in a hurry and I love to meditate a little and look into my fly boxes looking for a fly that I have never used in the hope of catching an unexpected large prey. Looking into my box, I have often wondered which flies would be ideal for a bamboo rod. You may say that there are no flies only for carbon rods or only for bamboo rods. You can use whatever fly – the classical ones or the modern ones – right up to the maximum expression of modern with the tendency to use synthetics which is in fashion today. So if bamboo represents a cure for the appreciation of the beauty of fly fishing and if its use is often accompanied by the simultaneous use of a beautiful reel, then why renounce to the fact that beauty may extent to the end of your line?

The history of flies is ancient and fascinating and it has always been tied to nature in the form of the natural materials that they were made from for centuries. Hairs, feathers and silk are all from animal origin and their characteristics – sheen, lightness and transparency have always represented what was sought after to be as close to the ethereal inconsistency of insects. These characteristics are non-reproducible by human chemistry. Even so, the appearance on the fly tying market of an enormous quantity of synthetics has given modern fly tiers the illusion that they have found a better substitute for the natural materials used until then. Foams, preformed bodies, polypropylene in various forms, glues of all kinds have given life to a race of experiments of new and often useless techniques to apply to fly tying. Undoubtedly, many of these flies are real killers even though do not even minimally have those natural components of nature and beauty that the classical flies had.

Often to justify the use of new materials and techniques, it has been said that the fact that trout are increasingly more selective calls for the need to propose new and innovative solutions as if the trout follow the rules of the marketing by modifying their feeding habits. In truth fish are fish and as such will continue to feed on insects that have lived in streams and rivers for millions of years.

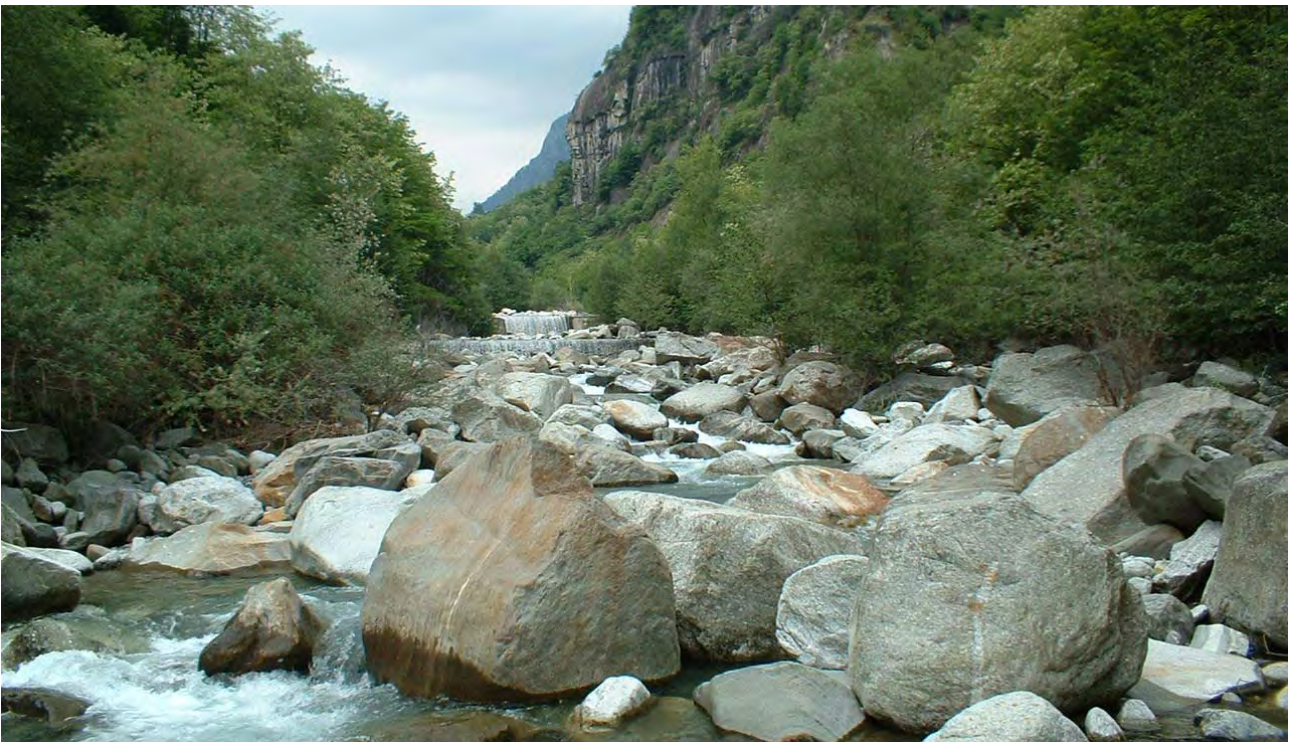

Thus is so strange to think that classical flies which were developed after careful study and tested successfully for decades can suddenly become unproductive and be abandoned forgotten in the draw of memories.

With great satisfaction I have realized in various occasions that flies that have been outdated for years can still make the difference in many situations on fish that have got used even to the abused CDC or other synthetic interpretations.

The little palmers for example like Hewitt's famous Bivisible, flies that have been almost abandoned but that have for many years been a constant presence in fly boxes. Then the mayflies tied classically like the Red quill, the Blue Dun, the Quill Gordon in which the bodies are made of peacock or of cock feathers are as imitative as they come. Or the ethereal Variants and Skaters with their oversized hackles which were so pleasant to skate and jump in the riffles.

These flies seem to have been developed to be fished with bamboo because its flexibility makes casting them easier without curling the leader and above all will help to get them to work properly with a particular technique. These Skaters (invented and loved by Hewitt) have become difficult to tie – not so much for the technique (simple and disarming) but for the proportions of the hackles. Cocks which have been selected for fly tying have very different characteristics to those of just a few years ago. Today hackles must be long, with constant length of the fibres from the tip to the base which are ideal to tie flies on small hooks. It is even difficult to select a good bunch of fibres to make tails for a classical mayfly. For Skaters, the ideal feathers were those from the lateral part of the old capes or the cock feathers called swords. Both had very long fibres to make Variants or Skaters with collars that were up to 5 cm in diameter.





Nature gives fly tiers an enormous variety of furs and feathers that are shiny and flexible in a unique way and that are inimitable with synthetics. The chromatic effect and the natural colorations of the feathers are extremely close to the tonalities that form bodies, wings and legs of real insects. The mottled feathers of a partridge, the iridescence of a peacock quill or a starling quill, the melange of a natural grey cock hackle are not reproducible by man. Nature, whether speaking about insect, feathers, fish, plants or earth, is an expression of a mixture of colours, streaks and shades. Even colours that to our eye look defined and uniform are always the results of a mix of shades and different tonalities. The writer and artist Jack Ather-ton, who was a great supporter of Impressionism in fishing flies, would mix feathers and furs to create an effect that would be very natural and without colours that were too defined, based on the theories we have just discussed above.

Also with the learning curve and growth of tying techniques, I found much affinity with Hewitt's three phases which in reality could be applied to Mankind in general and even to bamboo rodmaking. Inevitably the neophyte will tie all kinds of flies and will experiment with all kinds of techniques on his vice using all types of materials – natural or synthetic. In this process the influence that books and magazines have will be very relevant. He will be a copier, reproducing other tier's models. In the second phase he will tend to be a little more choosy with his materials and techniques, rejecting (but not everything) from the market and starting to experiment with his own models.

These experiments are often reduced to a simple substitution of parts of well known flies with new materials with the illusion of having created something new.

The birth of a style can take place in this period and the flies that are created will be the fruit of choices and trials on the river.

The last phase is the one of awareness, of the return to natural materials that have been abandoned for a long time and victimized on the altar of synthetic novelties. It is the phase of applied simplicity and the research of beauty in tying, the rediscovery of dated (by no means less effective) flies and perhaps the understanding that inventing something new in the world of fly tying today is an arduous undertaking. As was written by an American author, very time I think I have invented a new model or a new technique, I inevitably find it in a catalogue or in a new book published by someone else.

Even though in this process of growth you find phases that are sometimes quite distinct, there is a factor that is common to any moment spent at the tying vise and with any fly tied – a new one or one that has been tied many times before. It is always present and it is the certainty that we are creating something that sooner or later will connect us to a fish that will not be able to resist it. It is this conviction that allows tiers of flies to fish while they are seated and turning threads.

It is also true, as a good American friend says, that we should take ourselves too seriously. After all we are playing with parts of dead animals. As it is also true that we are playing with fishing equipment that are only instruments to be used. All this for the sake of a prey that is the trigger for our sport and even if as Thoreau wrote: "many fish their whole lives without even knowing that it is not the fish that they are after".

*Alberto Calzolari*





## Mario Chiari

### A great Rodmaker

By Riccardo Baerlocher



*During my frequent trips to Ticino in Switzerland, I had various discussions with the local fly fishermen and often the name of Mario Chiari would come out – an icon and almost a holy man for the Italian Swiss. I was curious and so I went to the inauguration of the Fishing Museum in Caslano where I had the opportunity of admiring his collection of flies and his rod-making tools (<http://www.museodellapesca.ch/>). The museum has dedicated a whole room to him and I was particularly taken by his completely unusual planing form. Mario was a true fly fishing pioneer in Canton Ticino but he isn't know outside the Swiss borders – perhaps because there was no Internet at the time and also because he was a very reserved man.*

*I asked my friend Riccardo Baerlocher, founder in 1977 and first chairman of CPMT (Club Pescatori a Mosca Ticino), to write an article for the Bamboo Journal so that this extraordinary man be introduced to all rodmakers. The photos of Mario Chiari in the article are not such good quality because they have been extracted from an old film which was televised by the Italian Swiss TV (TSI).*

*Alberto Poratelli*



*Riccardo Baerlocher with the Wife of Mario Chiari  
At the inauguration of the Museum of Caslano*

MARIO C. CHIARI -  
BREGANZONA – TICINO – CH  
1942 – 2004

Mario , was the son of an Austrian father and Italian Swiss mother. These two different cultures gave him a great open mind. He fluently spoke and wrote in 4 languages – Italian, French, German and English. This allowed him to have a well furnished collection of fishing books e was one of the reasons that opened the doors for him to work for the Swiss Italian TV at the end of the seventies.

I met him in 1958 in a Catholic College in German Switzerland and we in the same class for a year. In this way we got to know each other and found that we both had the same hobbies: Hi Fi's and SW amateur radios. I soon discovered that Mario had, what is known as golden fingers. He knew how to make or fix whatever came into his hands. He was well informed about technical things. We spoke little about fishing because we both fished with traditional methods in lakes. In those days we got around by bus or by bicycle.

In 1959 there was a big turning point. My parents bought me a Vespa 125c.c. which gave me independence and during the summer vacations, I would often go to Breganzona to see my friend.

Our studies and military service kept us busy until 1966, when I left for London for work. I stayed there three years but we often spoke by phone.

One day he wrote me a letter where he gave me the address of a fishing shop which was close to Piccadilly Circus and a list of things to buy for him. It was of course Hardy Bros.! I shopped for Mario regularly in this paradise where you could only find hexagonal bamboo rods. I discovered a new world – salmon flies, special hooks and other devilry. I remember the Portobello flea market where I would look for silver plated “marrow spoons” (a special spoon for getting to the bone marrow). In silver they used to cost a fortune but the silver plated ones only cost 15 shillings. Later Mario Explained that they could be used to check the stomach contents in trout so that you could choose the right fly! I found five of them and one is still in my fishing vest! So in this way I slowly got acquainted with the world of fly fishing and it was catching on.

He even send me to an optician in Regent Street to buy a pair of spectacles that he used to tie small flies (+ 18) . If we worked for a couple of hours his eyes would tire. These glasses cost £ 3.10 and they had a particularity. They had two triangular lenses that would correct the position of the eyes so that even after 4 hours of tiny work, his eyes would not get tired. I was discovering a fascinating world.



*The Museum of Fishing in Caslano*

Intrigued by all these novelties, I ask Mario which rod he suggested I purchase to start of as a fly fisherman. The answer was quite simple: Hardy Palakona 8'6 for a 6 weight. I ordered it just before returning definitely to Switzerland and I had it delivered to the "duty free" at London Airport. I thus saved the "purchase tax", a good 30% !

We went fishing together from 1970 onwards and he introduced me to his favourite river in ex Yugoslavia – the Krka – a wonderful "chalk stream" which I have visited every year with friends.

Thanks to Mario, I am probably the only Fly Fisherman who has learned to fish ...by correspondence!

In those years, Mario had acquired a vast experience in tying dry flies, nymphs and streamers but he also had fun tying beautiful salmon flies using only natural materials.

He became a wholesaler for the English company Veniard. This allowed us to get interesting prices for hooks, feathers and silk threads. He would tie many flies to order for wealthy customers from Zürich who even paid them well.

He purchased a used VW Bus which he transformed into a fully equipped fishing camper. Of course he did not forget a gas burner so that he could cook his meals along the river banks.

In 1977, the Canton Ticino introduced a law that prohibited fading which was particularly penalizing for the fly fishermen. There weren't many of us but we were prepared for anything. That's when together with other fly fishermen, we founded the CPMT (Club Pescatori a mosca Ticino) and in 182 the ban was lifted!



In 1979, together we were nominated Instructors by the Istituto dalla Federazione Svizzera di Casting (Swiss Federation of Casters which operated as part of the Swiss Federation of Fishing. With this solid base, we instructed new fly fishermen with the casting technique which was used in the whole of Switzerland. In the years to come, other CPMT members (Kerner, Oppliger) passed the instructor exam which allowed us to teach fly fishing.

From the mid 60's Mario wrote articles in German on fly fishing for the Magazine "Petri Heil", the most read magazine in the confederation and soon became the official editor for Italian Switzerland.

Mario was also editor of our Bulletin "Sedge" from 1980 until 1990 and which was printed three times a year. In this way we were kept informed on the latest around the world on fly fishing. At the time there were no PC's, so he used a typewriter and we would simply send photocopies to our members. The product was homemade but the contents were excellent.

If I'm not mistaken in 1984 Mario called me asking how long my trucks were. At the time I worked for an international transport company and did a lot of groupage work with England. I informed him that our trucks were S11 – 12 metres long! With a Telex he send me the address of a person in England who was selling his whole of bamboo what dated to the Second World War. The owner, who was 84 years old, couldn't hold his plane properly because of arthritis and so 10 days later I transported two bundles of bamboo that were about 4 metres long to Breganzona. Mario was the happiest man in the world! He finally had the raw material and it was even very well aged! With the help of the books by Garrison, Ernest Schwiebert and others he started making a very particular planing form which was also very expensive but in these things Mario was regardless of expense.

The best planes and micrometers, a small lathe, a drill, various disks of sand paper e of course spacers were the tools that he needed to make his first split cane rod! From that day, he transformed his garage in Breganzona into a rodmaking shop. His hand was often full of bandages until he understood the need to purchase a good pair of strong rubber gloves!

After a few prototypes, he showed me a novelty. A system for impregnating the bamboo which worked with a pipe connected to a water tap which would create a vacuum that allowed him to impregnate the



wood quickly. A safe method that would prevent it from decaying. In that period, Mario share d various ideas with a rodmaker friend - Marco Kerner. They would often go off to try their rods on the banks of the Krka.

I don't know how many rods he made, but I'm sure a great number because he really had a lot of bamboo. Now there are only a few culms left. Some of the club members have his rods, a memory of the past and also a precious relic. Since his room was so full of things and he needed space, one day he gave me a cabinet with this written on it: FLY TYING HEADQUARTERS e THINK TROUT !

A philosophy which is also reflected in his collection of "pins" – all well set out in an enormous frame which hung in his room and all them had some relation with fishing.

In the mid 90's the Fishing Museum of Caslano was inaugurated and the late Mr Chiesa asked him for some fly fishing material. Mario lent him a whole lot of things: rods, antique reels, flies etc. On his deathbed he expressed the desire that everything he had lent to the museum be transformed into a donation.



And so it was. In the new Fishing Museum in Caslano, you can admire all this memorabilia including his planing form. Thank you Mario! He was interviewed various times by the Televisione della Svizzera Italiana and TSI decided to make a documentary about him. The crew went to his famous garage shop in Breganzona to film the various stages of rodmaking. They edited it and transmitted a film that lasted 15 minutes. A beautiful memory.

He was famous for his jokes. He knew hundreds of them and also knew how to tell them. How much we laughed with him during the casting and tying classes.

One of his inventions is the “anti-ballbreaker fly”.

It was a streamer with a razor blade patiently tied to the curve of the hook. When an unsporting antagonist would cast his weighted bobber with five flies to the other side of the river to his feet, his streamer would come into action. He would cast his leader across the line and.... snip!!

In the nineties he underwent heart surgery in Zurich . 6 by passes!! He should have started relaxing but this wasn't his style. He continued living it up. He went fishing in Canada, Patagonia and he was one of the first to explore the Kamchatka peninsula after the fall of the Berlin wall. All beautiful places but his first love – the KRKA – remained his favourite destination right to the end. Even as his illness progressed, he satisfied his whim to catch a Danube salmon (Huchen) which was more than a metre long. He showed me the photo. He made me understand that it was his last big satisfaction.

Today much is said about “catch and release”. Mario used to say that he was against imposed solutions and that he would have accepted any imposition relating to fly fishing but he wanted to decide whether to kill or release a fish.



“ The only creature in nature that has the capacity to choose is man!) These are the final words of the Trout Unlimited video which was televised by TSI during the program Natura Amica (Our friend nature) about 20 years ago and that called “The adventures of a trout”.

During his life he personally met many fly fishing VIP. Everytime he went fishing on the Loue in France he would visit Dr. Jean. Paul PEQUEGNOT who wrote many books of fly fishing. With his wife Sandra he went to Holland to meet the famous reel maker Ari t'Hart from whom he purchased various jewels of the 80 and that are now collectors' items. I can consider myself lucky to have met Mario in 1958, a friend with golden hands that was my mentor. He was a complete fly fisherman – fly tyer, fisherman, casting, rodmaking. Thank you Mario.

Nothing has ever been achieved without enthusiasm!

This fits Mario perfectly. He had tons of enthusiasm!

Ciao Mario !

Riccardo Baerlocher





## A different approach to making bamboo ferrules

di Olar Ovidiu

It is a known fact that bamboo ferrules offer a more continuous action, a smaller weight, and a much better balance to a rod, than the classic ferrules made of nickel-silver, standard ferrules or even Super Z.

Making better, lighter rods is the desire of any bamboo maker. Having this in my mind, I have tried to work out a way to make these ferrules in a simple manner, with fewer tools and less effort.

My method is based on the height difference between the stations of the planing form.

The height is in direct connection with the width of a strip. Thus, working only with this value, it is enough to make bamboo ferrules.

To make things more clear, I will explain it in a few steps, beginning with the planing form transformation, required to make these ferrules.

### 1. Planing form "transformation"

Most of the planing forms have 13 stations, but I am sure that very few of us use the last 2-3 stations. So, for this reason, I have "ruined" the last 2 stations in order to get something good.

Modifying the groove between the last 2 stations of the planing form is based on the ferrule wall thickness that is needed. To get a wall thickness of 1mm we will increase the depth of the groove by 1,1mm. The extra 0,1mm leaves enough material for sanding the finished rod section without affecting the wall thickness.

If a thicker wall is wanted, for example 1,3 mm, the groove has to be deeper:  $1,3+0,1=1,4\text{mm}$ .

The point from where we will make the groove deeper by 1,1 mm is 2,5 cm (1") from the 55" station of the planing form. This length will offer a smooth pass from the width part of the ferrule to the taper dimension. It is possible, by choice, to make that even shorter, but in this case, it is necessary to heat the strips when they are put together for the final assembly.

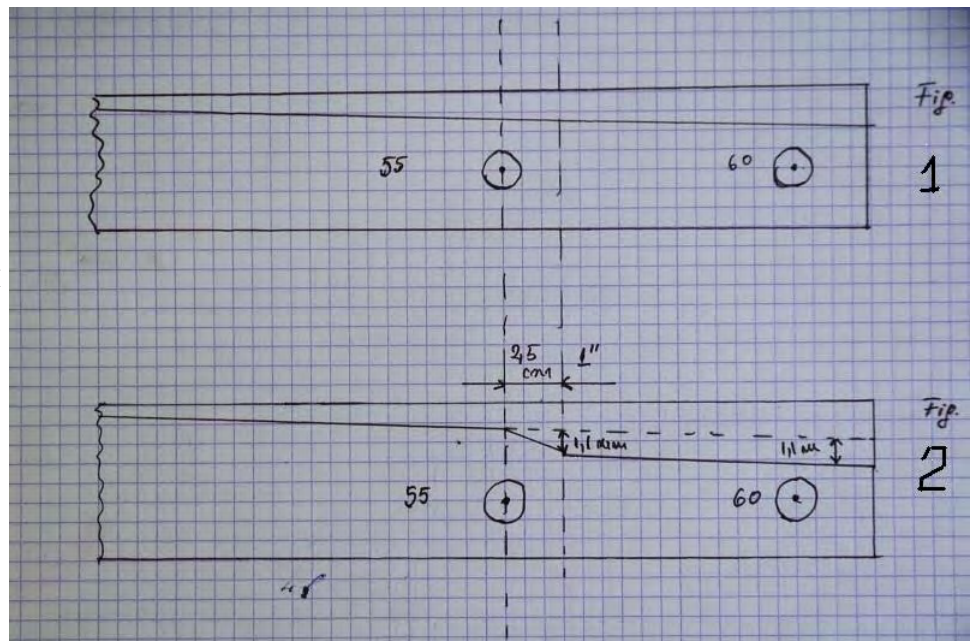

A schematic view of the modified planing form. (photo 1)

The groove can also be made parallel, but in this case the taper needs to be modified because the walls of the female ferrule will be parallel.

By keeping the decrease, and making the groove following this decrease, the taper remains the same, and more, the friction that holds the ferrules together is also generated by the coning of the taper.

To make these changes on the planing form, you will only need these tools.



The method applied is one described by Thomas Penrose, with a few differences.

The station before the one we are modifying (in this case station 50) needs to be open wide enough. In this manner the reamer will not remove any material from the station 55" (2,5 cm after this station the deeper groove begins). The station 55' needs to remain intact, because there is the reference point of the taper before the ferrule.

## 2. Strips preparation

-the strips are made in the same manner as for any rod, with 2 differences.

-first, make the strips wider than normal;

-secondly, the length of the strips is calculated as follows:

Ex.: if the tip section length is 100cm (40") we will add 2,5 cm(1") the length needed for the slope, (the part where the ferrule begins, and gets thinner to the required value of taper at the station) and 5 cm, the actual length of the ferrule.

The total length is  $100\text{cm} + 2,5\text{cm} + 5\text{cm} = 107,5\text{cm}$ . If you add another 1 or 2 cm in length, it will help you repair any mistakes that could appear during the planing. This excess can be cut away after the strips are glued together, to get the desired length of ferrule.

## 3. Planing the strips

The planing form is set as the taper requires, except that at the last 2 stations the depth of the groove is set 1,2 mm bigger than the taper.

The last station of the rod section, in our case 40, the value to set is  $1,8 + 1,2\text{mm} = 3,00\text{mm}$ ; the next station 45, and it is set at the value  $1,9 + 1,2 = 3,1\text{mm}$ ; even though from 40 station the strip has only 7,5 cm, and does not arrive at the 45 station.

It is better to leave the strips larger with 0,1, up to 0,3 mm, this way any mistakes can be corrected without ruining the strips.

-all 6 strips are planed this way

-we mark with a pen, each strip at the last station, before the 7,5cm

The modified part of the planing is set as following:

Ex: we have a rod ,4wt, 2 pieces .

I have chosen random values, just as an example.

The middle part of the taper (the half of the rod) is at the station 40

Taper dimensions

.....35-1,6mm, 40-1,8 mm,45-1,9mm,50-2mm,55-2,2mm.....

So the last station for the tip section is 40 with the value of 1,8mm

The first station of the butt section is 0 (as we set this when planing) with the value 1,8mm; the next station of the butt section has the value of 1,9mm.

We set the planing for making the ferrule as follows:

The 55 station of the planing is set to the value of 1,8mm (the value of the tip at the last point of the taper)

The station 60 is set at  $1,9\text{mm} + 1,1\text{mm} = 3\text{mm}$  (the second station of taper from the butt section has the value 1,9)

The station 50 is set at the value 1,6mm (the value of the station 35 from the tip section taper)

Setting only these 3 stations is enough not to make any mistakes. If you want, you can also adjust the other stations ahead.

The strips are put in this groove with the mark that we have made early at the station 55 (foto2).

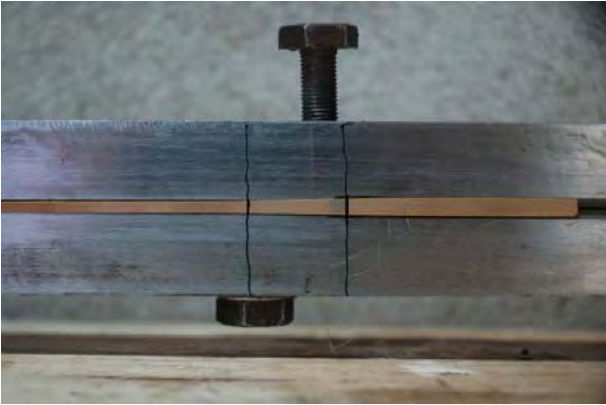

Any extra marks are good.

All the strips are planed in this groove, carefully removing small parts of the section, one side-one pass of the plane. In this way, we will get even slopes on each side of the strip.

When all the strips are planed, we get to the "hollowing" process. (photo3).



The next step is the preliminary assembly, so we can see if there are any gaps between the strips, or if the strips are not planed equally. (photo 4)



As it can be seen in this photo, the total length of the ferrule and the part with the slope is 7,5cm.

In my opinion, this length is more than enough to offer strength and not to lose the elasticity of the rod.

The length of the ferrules is according to the weight of the rod. For a 2 wt rod the length of the ferrule of 3,5 cm is more than enough. For a 3 wt, 3,5 –4 cm, for a 5wt, 5 -5,5cm.

For those who choose to make the wall thickness bigger than 1mm, the ferrule can be made shorter.

The advantages of this type of ferrules are obvious for everyone, regarding benefits of the finished rod.

Another main advantage is that the tools required are minimal, everyone already has them in the "genesis chamber" of bamboo rods.

Also the cost for producing these ferrules is very low, even if the time needed is much longer as precision is a very important factor.

*Olar Ovidiu*

[www.ovidiusrods.com](http://www.ovidiusrods.com)





ANDREA SATTO  
WOOD FLY REELMAKER

By Alberto Poratelli

In the fly fishing world, it often happens that you discover people with a particular talent. True artists – on the other hand, fly fishing is an activity that is very close to the arts. Among bamboo rodmakers, there are some real artists that make rods which are beautiful, even in the eyes of a non-fisherman.

Bamboo rodmakers have a great love for wood and so we appreciate those who know how to work with it and know how to valorise it, especially if it concerns our passion





One of these magnificent people is Andrea Satto or “Mandi” for his friends. He hails from Merano and he has learned how to mix the fruits of his experience on the lathe with his passion for fly fishing and the genality of his ideas.

I met him a few years ago during a Rodmakers Gathering in Sansepolcro (Italy) and I had the fortune to admire his beautiful reels (I was also fortunate enough to become the proud owner of one of these works of art). From then he has always been a guest at our gatherings, exhibiting his reels next to our rods.





Andrea says about himself:

*"Like it has for most of us, everything started with the great passion for fly fishing, a passion that evolved into creating my flies on the vise and beyond that didn't break into making fishing rods but, maybe influenced by my fitter and turner profession, broke into building "my" reel in aluminium, which I have used on many rivers for several years.*

*A few years after the completion of the first reel, I am intrigued by a friend, who told me about seeing some hand-made wood reels in an exposition. At first I was quite amazed and hesitant (wood isn't the best material when in contact with water), but then I decided to try it myself. The first productions in wood were quite good, but weren't fully satisfying, also because of the fact that in the meantime I had discovered who was behind those fantastic reels they had told me about: the person I consider the "master", Giorgio Dallari.*

*I decided then to put more effort into creating something beautiful that could really be interesting for the passionate fly-fisher, following the path marked by Dallari.*

*My idea is to bind the various woods that nature provides us with, among which amboyna and thuja combined with metals of all sorts, such as aluminium and bronze, creating unique pieces each different from the other, and inventing several models with a distinct design."*

The reels Andrea created truly are unique pieces that he personally draws and creates, you will not find two "Mandi Reels" alike, because each one is a masterpiece.

Andrea Satto doesn't have an Internet website (yet) where he can show his work, but I think he will see to that quite soon. If you wish to contact him his e-mail address is: [www.mandi-reels.it](http://www.mandi-reels.it)





## Argentina Bamboo Week

February -March 2011

### Diary of a dream

*By Massimo Tirocchi*

There are only a few places left in the world where nature has the power to surprise you with its original beauty.

There are even less that can offer fly fishermen authentic, unique and unforgettable fishing experiences. Among these natural paradises the Argentinean Patagonia has always had a special place in my thoughts.

Often while sitting on the banks of a stream waiting for the evening hatch, my fantasy has taken me to the famous Patagonian Rivers waiting for the gentle rise of a wild Brown Trout (a Marron as it is called in those areas) under a bush taking the small mayflies floating down with the current.

So when last October 2010, the guys from Andes Drifters invited me to the first edition of the Patagonia Bamboo Week, it took me a few seconds to decide that a few months after that part of my dreams as a fly fisherman and as a rodmaker were becoming real.

Looking at the programme of the Patagonian week, I noticed that the organization would not have let us want for anything in terms of logistics and variety of rivers we would have fished in.

The rivers were in fact very heterogeneous as far as size, amount of water and geomorphologic characteristics of the surrounding territories and of course in all there was the possibility to catch extra large trout.

All this would have put my rods to a very strenuous test that wouldn't have been easy to pass in a dignified way.

Fishing on the Malleo meant fishing on the dry large and wild brown trout and rainbows (18-28 inches); all this in a typical Spring Creek setting.

The Collon Cura is instead a big river where even though you fish from a boat,

it was necessary to cast long with dry flies, nymphs and floating minnows. Finally there was the Chimeuin, an explosive combination of the first two rivers I have described.

On all rivers there was the wind factor which fortunately wasn't always present and with a decisively lesser intensity to the perennial wind of southern Patagonia.

So very big fish, very big rivers, a variety of flies and wind – all of which made a nice challenge for my rods and as if this wasn't enough, just like a cherry on the cake, the characteristics of my rods.

Since I started fishing at the end of the 80's, I absorbed the typical and what is known as the Italian Style of casting.

Without going into detail, the Italian Style of Casting is centred on line speed, light lines and short rods (2,3 and 4) and of course the prevailing use of the dry fly.

This technical background has naturally influences the way my rods are conceived and used. In other words, all this has led to the best possible trade off between rod action (preferring progressive more or less fast ones), weight of the rod, its distribution along the taper and the balancing point.

In numbers this covers a range from 6' to 7'5" to use with lines from 2 to 4.

After the initial enthusiasm for this adventure, my question was: "Would my rods be able to stand these tests without breaking?"

This doubt was further corroborated by other elements.

Firstly at the Bamboo Week, there would have been 5 gentlemen from various areas of the US that would have used my rods.

Now as we know, in the US they are not used to using equipment that can be defined as light.



So with my luggage and my rod tubes I left from Fiumicino airport full of doubts and fears. We boarded at 18.00 on Aerolineas Argentina and after a total flight of 20 hours we arrived in San Martin de Los Andes.

During the welcome luncheon at the Spring Creek Lodge of San Junin de Los Andes I met the guys with whom I would have shared the adventure: Robbie and Brian from North Carolina, Jon from Massachusetts, John from New Jersey and Steve from Pennsylvania. So during the meal and a glass of wonderful Malbec and another, we discussed various fishing issues and above all fly fishing with bamboo rods. As soon as lunch was over, we went to the lawn in front of the lodge where we had a preliminary session of casting with my rods. This was necessary to create the correct feeling between the rod and the fisherman that would have used it on the river.

So I took out my rods and with surprised faces,

on the thousands of prejudices that are in the minds of many fishermen regarding bamboo rods. I'm referring to the fragility, the weight, to the fact that you can only balance the rod with a heavy reel, to the impossibility to fish in windy conditions, to the impossibility to cast great distances and to land big fish. What I was interested in was to put them in the condition to use those rods. All the rest would have come by itself. I don't consider myself a great caster but I have had the possibility of fishing with experts in the Italian style and of course the many times I have seen the demonstrations by the grand Master.

So it wasn't so difficult for me to demonstrate what is meant by Italian Style and how that technique transformed those fragile twigs into stilettos that could cast lines to great distances with tight loops and high line speed that would penetrate the wind.



they soon realized that what they saw was far from they were expecting. Eight foot 5 weight rods? No, 6'3" and 7'2" for a three weight line. Suddenly on their faces appeared ironic and surprised smiles .

In that moment I wasn't interested in debating

I recall the example I used where casting the traditional way was like a Jumbo jet in flight, while casting the Italian Style is like the flight of a fighter jet.



We dedicated less than three hours on the lawn to transfer the concepts of the Italian Style when used with bamboo that everyone could acquire confidence with bamboo rods so that they could tackle the minsters of the Malleo. Every evening when returning to the lodge, or at the camp site along the river, the faces of these gentlemen no longer had the irony smile but their eyes were full of joy and satisfaction for the wonderful experiences lived on the river where catching trout with incredible colours gave them great adrenalin rushes. On my part I could not but be happy in seeing people who are used to fishing with bulky rods, taking joy out of using rods that until a few days earlier, we not considered worthy of those conditions. I won't hide the fact that I feared for the safety of my little creations, like the time that Brian with a 6'3" rod and bamboo ferrule fight a 28" Malleo brown trout for 20 minutes, or the time on the Collon Cura during the minnow run that Steve landed a 30 inch rainbow on a four weight 7'2". But the biggest joy was when at the end of the week, I proudly put my rods away without having me or the fishermen lose faith in any of them.

The world of rodmaking has made great progress in these last years as far as innovation, construction techniques, materials, taper design and therefore action. In this innovative trend I feel that the European movement has played an important role and all this was possible thanks to the courage of some rodmakers. This courage has allowed them to come away from the roads followed by their colleagues who are very often bewitched by the American tradition and passively continuing on this road.

Of course I recognize the historical value of the American School, but the Europeans have really brought something new into this fantastic world of rodmaking. In the European context, the Italian movement even though it is one of the more recent ones is characterized by another character that would be a pity to not consider as part of the way we design our rod. I'm referring of course to that wonder gift that was offered to us by the inventor of TLT, Roberto Pragliola. The technical heritage he is leaving, allows the Italian rodmakers to make very performing rods that are ideal for TLT. Roberto Pragliola loves to define TLT as the technique that starts where the others end and on this path which was cut by the Master, the Italian Rodmaking can be the expression of rodmaking which begins where the classical techniques have stopped 25 years ago.

If I may make a bold comparison with the world of literature, for me TLT is something very similar to what Italo Calvino indicated as the characteristics of literature of the new millennium: lightness, speed, precision and multiplicity. I see these characteristics in TLT and I would like them to constitute the basic elements for the design of my bamboo rods.



In this article I could have told you about the wonderful nature in Patagonia, the breathtaking sunsets under the vigil eye of the volcano Lanin, of the way the trout fight and their incredible colours.

All this would have meant trying to describe wonderful and unforgettable emotions. Since I am not an author of books, the task would have been too arduous.

Most certainly, fishing in Northern Patagonia with bamboo rods, is a unique experience one should try at least once in a life time. I hope to relive it again in February 2012.

*Massimo Tirocchi*







# European Gathering 2011

Immagini dal Raduno











## EXPERIMENTS

### WITH VARIOUS TYPES OF SECTIONS

§§§

By Marco Giardina e Gabriele Gori

This work is an experimental test of the results of theoretical research of various types of sections that are used in rodmaking. It follows the work "Confronting Sections" which was presented in 2007 in Waischenfeld at the German Gathering and followed up at the 1st European Gathering in 2008. The object was to evaluate and quantify the effective differences in the dynamics of the rods generated by different types of sections.

A brief reminder of the concepts:

#### Efficiency

A section that with the same weight is more rigid is more efficient. We probably all agree on this point, because it lets us have lighter rods with the same actions.

#### The weight

The weight is directly proportional to the area of the geometrical section of the rod and we presume that the material is always the same and that it has the same density.

#### Rigidity

Rigidity is the resistance a rod has to flexing and it is directly proportional to the elastic modulus of the material it is made of (that identifies the rigidity to flexing, in relationship to the "quality" of the material), and the moment of inertia of the sections (this represents the rigidity to flexing in relationship to the shape of the transversal section). If we consider that the material is always the same, in our case bamboo, the rigidity will depend entirely on the moment of inertia of the section.

#### The moment of inertia

This is a characteristic of a geometrical figure that identifies the resistance that it offers to flexing.

It considers the shape of the section that is how the surface (mass) is distributed in the section with respect to the flexing axis. Everyone has experienced the fact that a rectangular strip is stiffer if we try to bend it perpendicularly on one or other of the planes. The area (weight) is the same but the rigidity is very different.

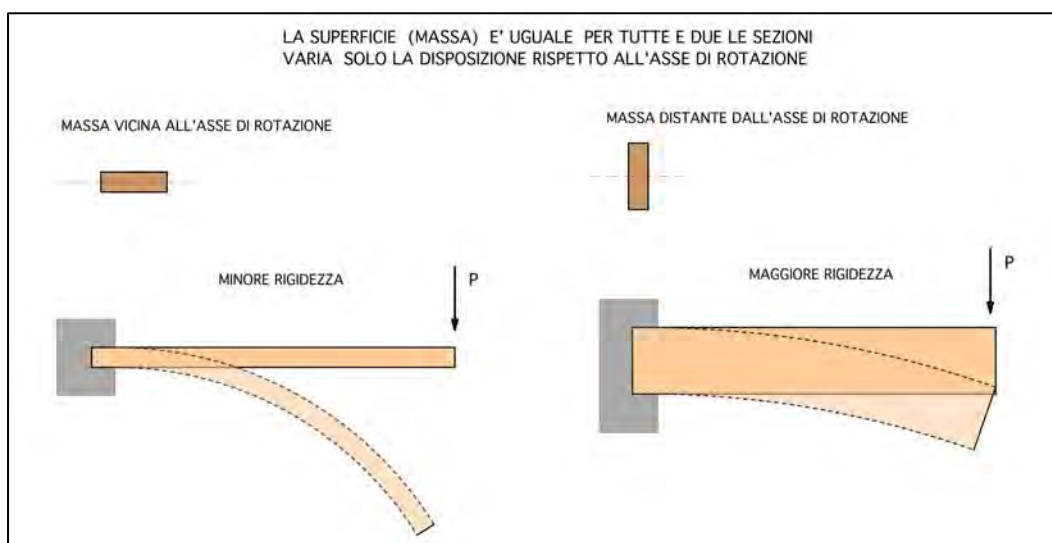

Very geometrical figure whether quadrate, penta, hex octagonal, hollow quadrate have a different moment of inertia because the mass, although the same is distributed differently.

For our needs, all we need to know is that if we take a series of strips of different forms triangular, hexagonal etc, all with the same length and of the same material and we apply the same load after having blocked one end in a vise, we will see that they all deform in the same way if they have the same moment of inertia.

The Table "Confronting Sections" is this: it confronts various sections in bamboo rods which are all different, hollow, fluted etc but that all have the same moment of inertia and consequently keeping all other factors constant, the same rigidity to flexing.

### Speed and Frequency

Let's recall the concept of speed of a rod: if we deform a rod and release it, the rod will go back to its original position in a certain time: the shorter the time the faster the rod. Speed is tied to the natural frequency with which a rod vibrates.

In order to find the natural frequency of a rod, we start by oscillating it with a slow frequency i.e. moving the hand forwards and backs slowly: the rod moves following the movement of the hand and the amplitude of the movement of the tip is proportional to the movement of the hand. That is a small movement of the hand equals a small movement of the tip, a bigger amplitude of movement and the larger the amplitude of the movement of the tip.

If you increase the frequency of the oscillation of the hand, you get to a point in which the movement of the tip is vast even if the movement of the hand is small. Any further thrust even a small one adds to the previous one and the oscillations increase more and more: in theory this can continue infinitely until the breaking of the rod. In reality in the real world a dampening process takes place (both by the material and by the air resistance) which dissipates energy through friction and this limits the amplitude of the deformation of the rod so that the system eventually finds a dynamic equilibrium.

This is the natural frequency of the rod. .

Clearly every rod has its frequency and this is higher (i.e. the rod is faster) if the rod is shorter, the lower the centre of gravity (distribution of masses i.e. the taper) and the higher the modulus of the rod.





Now if we increase the frequency of the hand, we will see that the deformation of the rod decreases considerably and at the same time it assumes a different shape. A reverse curve is generated i.e. a fulcrum which is about a third of the way from the tip of the rod and we note that the movement of the rod is no longer in phase with the hand i.e. when the hand moves forward the tip moves backwards.

This is the second way of vibrating of a rod and which comes into play in certain phases of casting: to observe it in a simple way, all you need to do is place the rod in front of a sheet of paper hung vertically and parallel to it. Move the rod forwards with a sharp thrust and the tip will move in the opposite direction and it will hit the paper. Then by increasing the frequency you get other ways of vibrating but the discussion would become too long.

### Measuring the frequency

To measure the natural frequency of rods (first way of vibrating) we used a machine with an electric motor with an inverter which by means of a crank mechanism gives a linear movement to a metal rod on ball bearings.

To one extremity there is a support to attach the rods on. The movements are constant and fluid and are calculated by means of a laser rev counter. The rods are attached according to their spine.

The natural frequency is determined as the one where you get the largest amplitude of movement just before that transitory moment that precludes the second way of vibrating.

### The test

This was carried out with an Octagonal 8' three piece rod with fluted butt and mid section.

The two tips for obvious reasons are solid but one is octagonal and the other quadrate. .

The taper was converted to maintain the same moment of inertia.

These two sections were chosen because they are practically at the extremes on the scale of efficiency of the sections which decreases with the increase in number of sides.

FORMA SHAPE COSTRUZIONE CONSTRUCTION	QUADRATA / QUAD	PENTAGONALE / PENTA	ESAGONALE / HEX	EPTAGONALE PIENA / EPTA	OTTAGONALE / OCTA
PIENA SOLID	<p>Area: 100.00 mm<sup>2</sup> Ixx: 833.33 mm<sup>4</sup> Ccx: 5.00 mm Wxx: 166.67 mm<sup>3</sup></p>	<p>Area: 101.48 mm<sup>2</sup> Ixx: 811.39 mm<sup>4</sup> Ccx1: 6.53 mm Ccx2: 5.29 mm Wxx1: 127.57 mm<sup>3</sup> Wxx2: 157.54 mm<sup>3</sup></p>	<p>Area: 101.94 mm<sup>2</sup> Ixx: 833.27 mm<sup>4</sup> Ccx: 5.42 mm Wxx: 153.61 mm<sup>3</sup></p>	<p>Area: 102.13 mm<sup>2</sup> Ixx: 833.32 mm<sup>4</sup> Ccx1: 6.11 mm Ccx2: 5.51 mm Wxx1: 136.40 mm<sup>3</sup> Wxx2: 151.23 mm<sup>3</sup></p>	<p>Area: 102.21 mm<sup>2</sup> Ixx: 833.29 mm<sup>4</sup> Ccx: 5.55 mm Wxx: 150.04 mm<sup>3</sup></p>

The solid octagonal section has a mass that is 2,21% higher than the solid quad section: the object of the test was to measure and evaluate how much this difference affects the dynamics of the rod.

### The results

The natural frequencies determined are the following:

Octagonal tip 130 cycles per minute

Quadrate tip 131,5 cycles per minute

The following are two images of the rods during the measurements

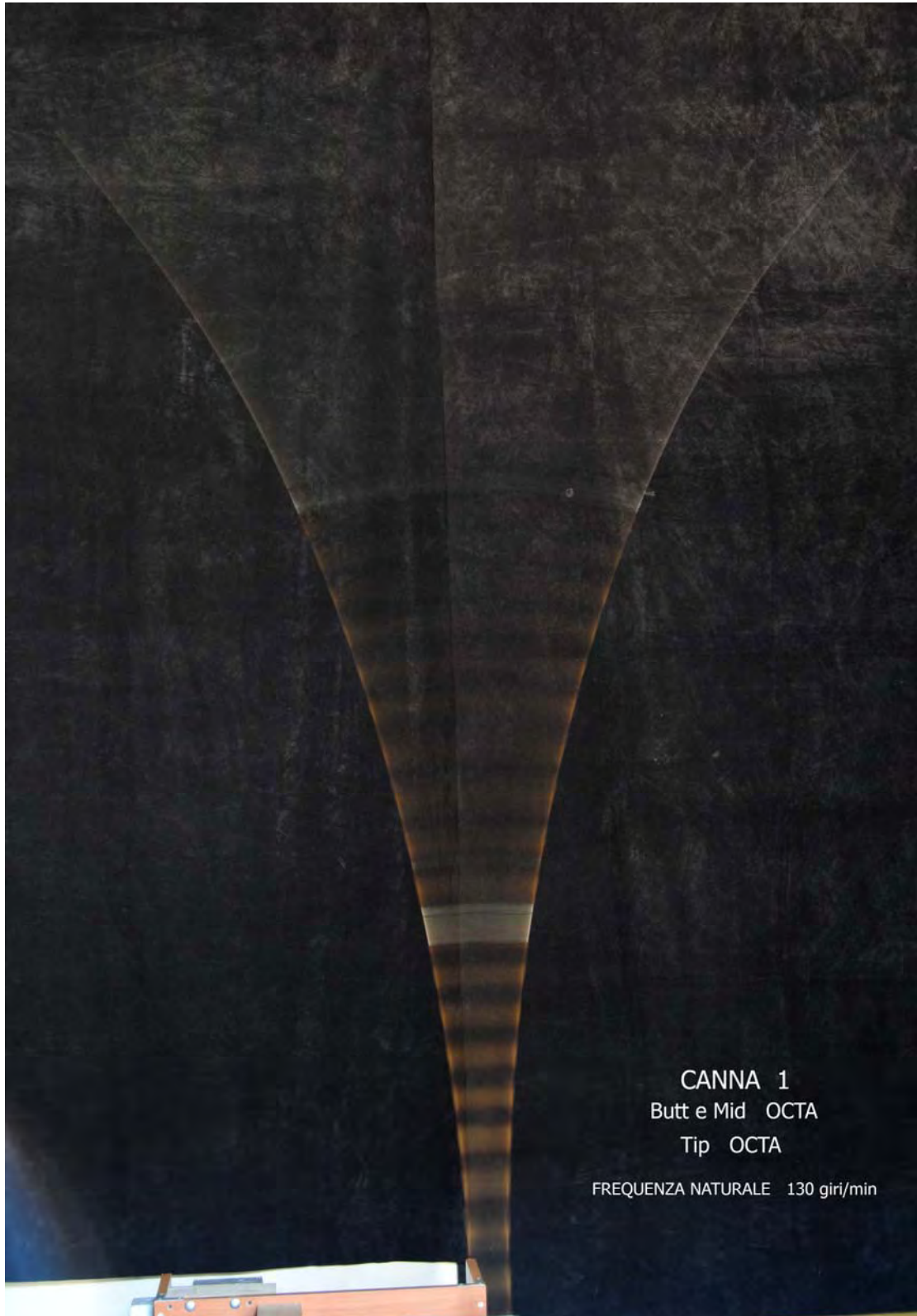

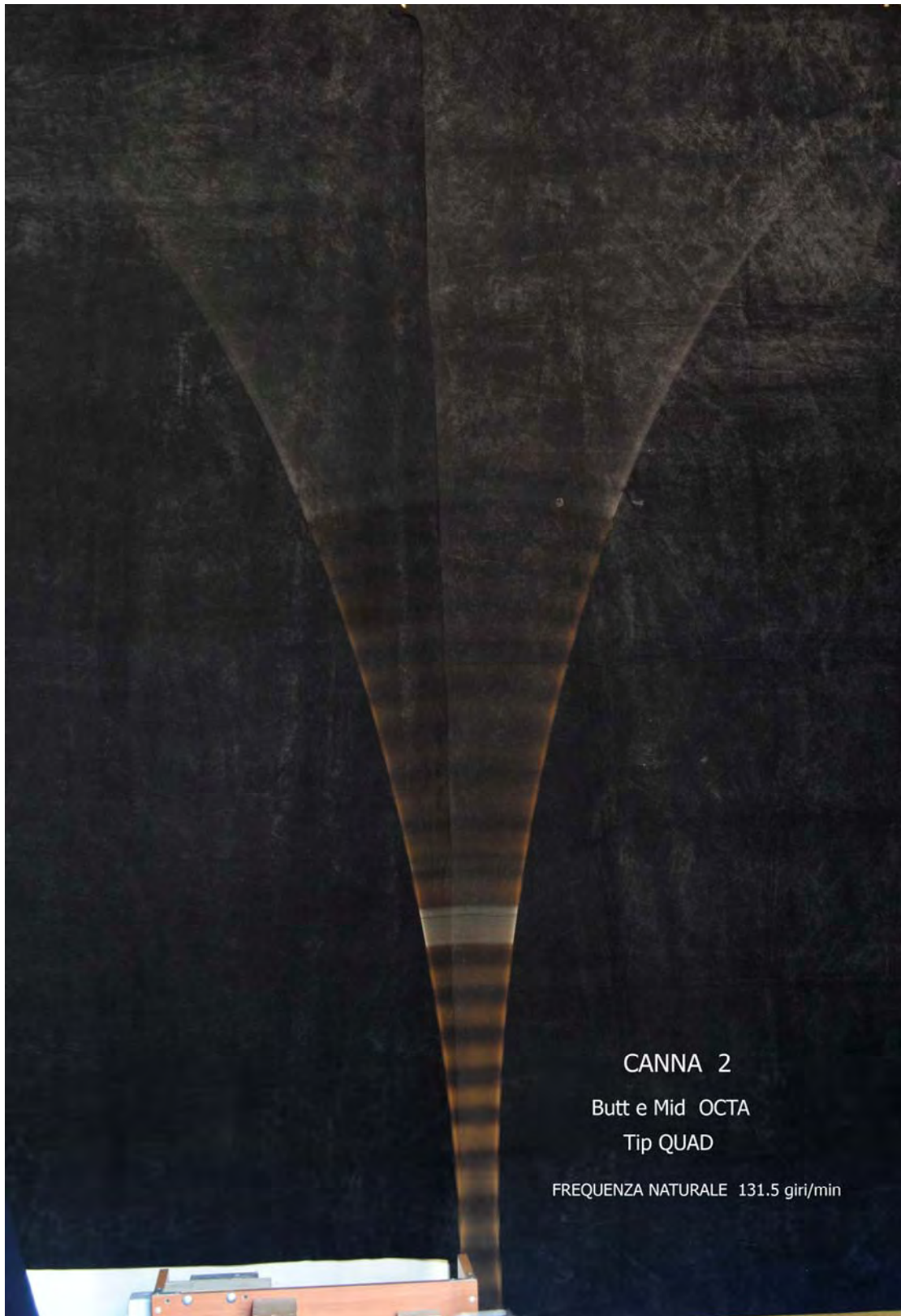

**THE PROFILES**



*OCTAGONAL TIP*



*QUADRATE TIP*



— CIMINO OTTAGONALE / OCTA TIP  
— CIMINO QUADRATO / QUAD TIP

### Confronting the theoretical data with the test results

The frequency is inversely proportional to the square root of the mass.

Since the mass of the octagonal rod is 1,0221 times the mass of the quadrate rod, the expected increase of the frequency will be  $\sqrt{1,0221} = 1,014$  i.e. 1,4%

The measurements gave a value of 130 cycles per minute for the octagonal rod and of 131,5 for the quadrate i.e. an increase of 1,1% which agrees with the theoretical data considering that the quadrate section was limited to the tip section only and not to the whole rod.

### Conclusions

The first observation that we feel that we can make is that the experimental results agree with the theoretical ones. The second observation is that by varying from one geometrical section to another, the differences in the actions are quite small but not negligible.

The shape when varying from quadrate to octagonal determines a difference in weight of the rod that can be quantified as a maximum of 2,21% .

The decrease in weight causes the frequency to increase progressively from the octagonal to the quadrate to a maximum value of 1,4%

If we consider hollow sections, the values will obviously change sensibly in favour of the latter which can be seen in the table "Confronting Sections" .

Unfortunately the problem of hollowing the tips remains and this prevents us from removing mass in the place where a decrease in weight would give the most relevant results.

You can't have everything in life.....





# Discussions on “Shark Tooth” Hollowing

*Di Gabriele Gori e Alberto Poratelli*

*Part One : Alberto Poratelli*

**T**he idea for the hollowing which is known as “Shark Tooth” comes from reading an article by Bob Maulucci ...

## **Making Hollow Rods: Beginnings**

*Article and drawings by Bob Maulucci*

### **History of the Hollow Rod**

I have always been fascinated by the ingenuity of America’s Western rodmakers. California rodmakers Lew Stoner (co-founder of R.L. Winston Rod Company) and E.C. Powell created some of the most forward thinking rods of the classic era.

I In studying both men, it is easy to see that their rods were influenced by the casting clubs as well as by the steelhead and trout that raced up California’s tributaries. ...

... from the study of the patents by two great rodmakers ...

**Lev Stoner**



**E.C. Powell**

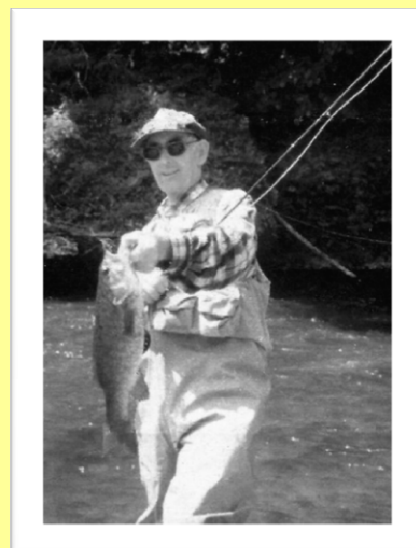

E.C. POWELL PATENT

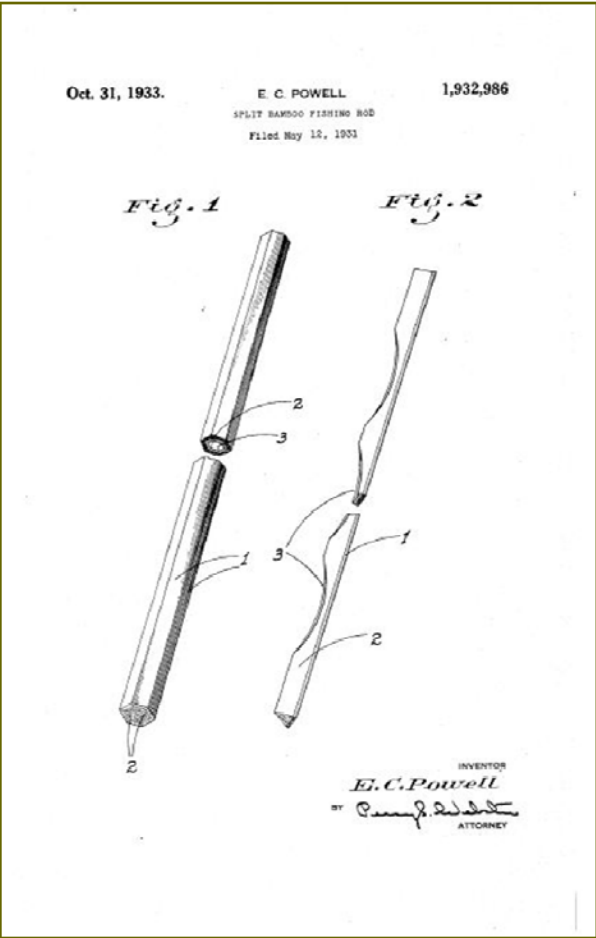

LEV STONER PATENT

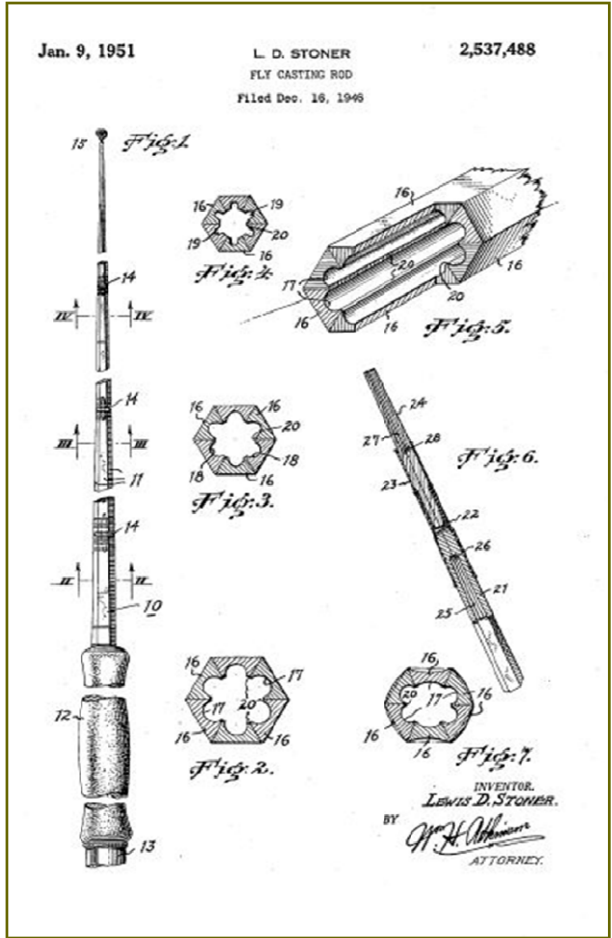

... and from the observation of components used in construction work:

hollow core slabs

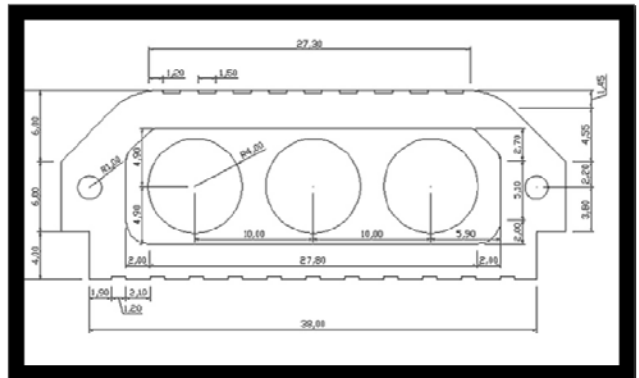



From these observations my project of alveolar hollowing of the blank was born.

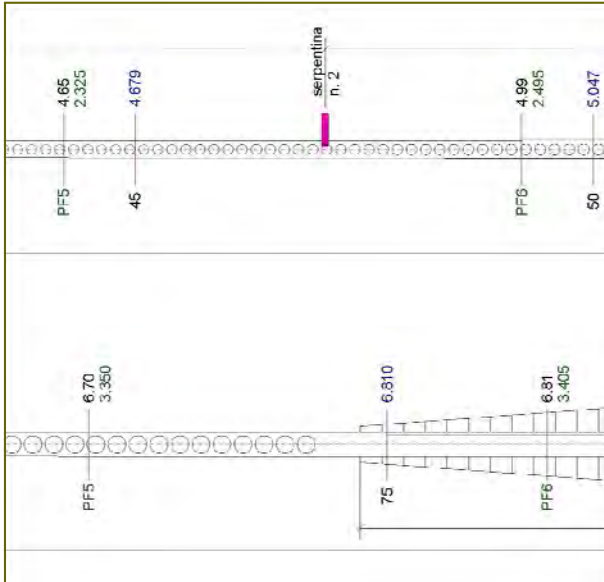

During the 2010 Gathering, I had introduces some works on this type of hollowing from which some particular characteristics emerge.

I had carried out these studies using a 3D CAD software which let me verify the surface areas and the volumes referred to three types of hollowing.

**E.C. Powell Hollowing**

svuotatura normale hollow normal			
altezza listello	mm. 4,00	height strip	mm. 4,00
spessore minimo parete	mm. 1,80	wall tickness	mm. 1,80
lunghezza vuoti	mm. 60,00	empty lenght	mm. 60,00
lunghezza pieni	mm. 10,00	solid lenght	mm. 10,00
percentuale di svuotatura	25,7%	percentage of empty	25,7%

**Lev Stoner Hollowing**

svuotatura fluted  
hollow fluted

altezza listello	mm. 4,00	height strip	mm. 4,00
spessore minimo parete	mm. 1,00.	wall tickness	mm. 1,00.
percentuale di svuotatura	43,9%	percentage of empty	43,9%

**Alveolar or spherical hollowing**

svuotatura sferica  
hollow spherical

altezza listello	mm. 4,00	height strip	mm. 4,00
spessore minimo parete	mm. 1,00.	wall tickness	mm. 1,00.
percentuale di svuotatura	32,2%	percentage of empty	32,2%

**Comparative table**

		tipo di svuotatura		
		tipo Powell	tipo Stoner	Shark Tooth
altezza del listello	mm.	4,00	4,00	4,00
spessore minimo parete	mm.	1,80	1,00	1,00
lunghezza vuoti	mm.	60,00	-	-
lunghezza pieni	mm.	10,00	-	-
percentuale di svuotatura		25,7%	43,9%	32,2%

The strips which are hollowed using a simple round file before gluing have a particular conformation that suggested Moreno Borriero to call it "Shark Tooth".

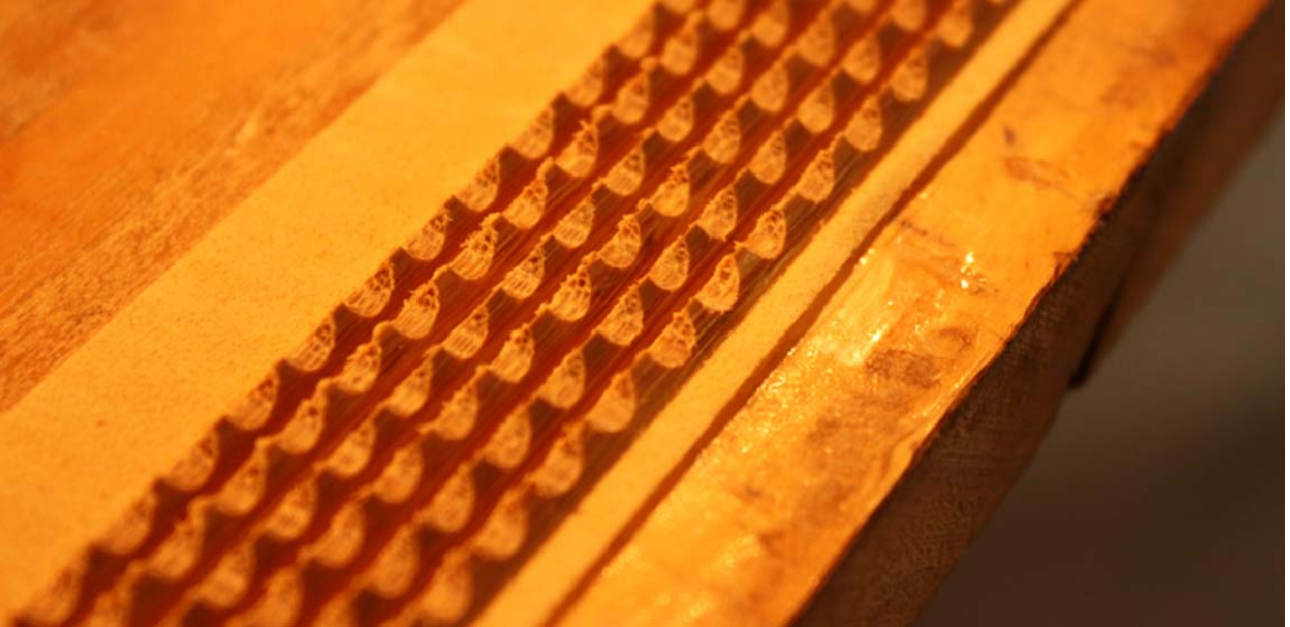

Two identical blanks which were made from strips from the same culm and heat treated at the same time which were subjected to flexing under the same weight applied to the tip gave a surprising result.

They flexed the exact same way.!

*The two blanks at rest :*

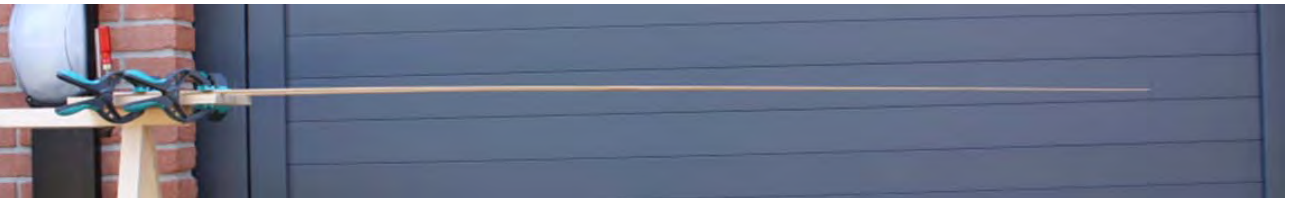

*The Shark tooth hollowed with a weight and the solid rod at rest.*



*Both blanks loaded, the flexing is very similar:*



At this point Gabriele Gori made a scientific evaluation about this.

#### *Part Two : Gabriele Gori*

Once Alberto had developed the Shark Tooth hollowing method, it was necessary to determine the coefficients to get the taper starting from a known solid taper and to compare it to other methods so that Rod-makers would have something to help with their choices.

But it's not so easy.

The fluted hollowing is effectively a continuous one for the whole length of the rod and in any section the rod is hollow the classical floral shape.



The rigidity with respect to the flexing of the section is determined by the moment of inertia in the figure

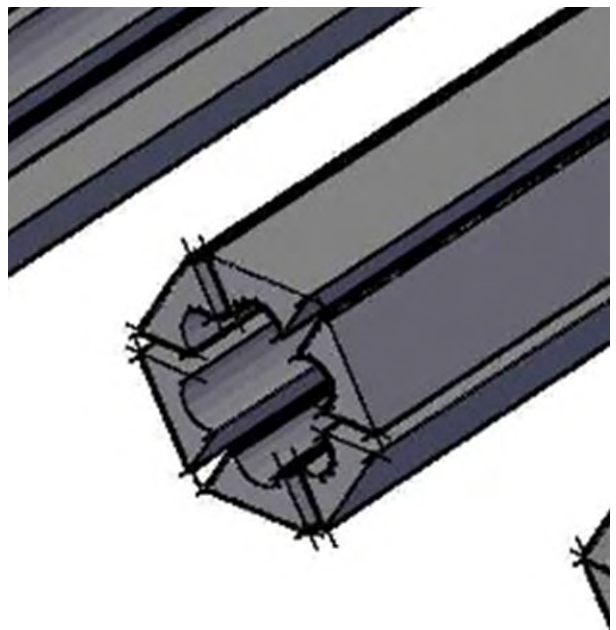

The scalloped version doesn't have the same continuity as the fluted. In fact there are hollow parts alternating with solid parts.



However the solid parts are rather far apart and a lot smaller than the hollow parts: in reality the solid parts are there to prevent the ovalization of the section, just as the diaphragms do in the culm. We do not commit an error if we neglect the solid parts that is considering the whole section as if it were hollow all along just like a fluted one.

Also in this case, we can estimate almost exactly that the rigidity with respect to the flexion of the section is determined by the moment of inertia of the hollow part.

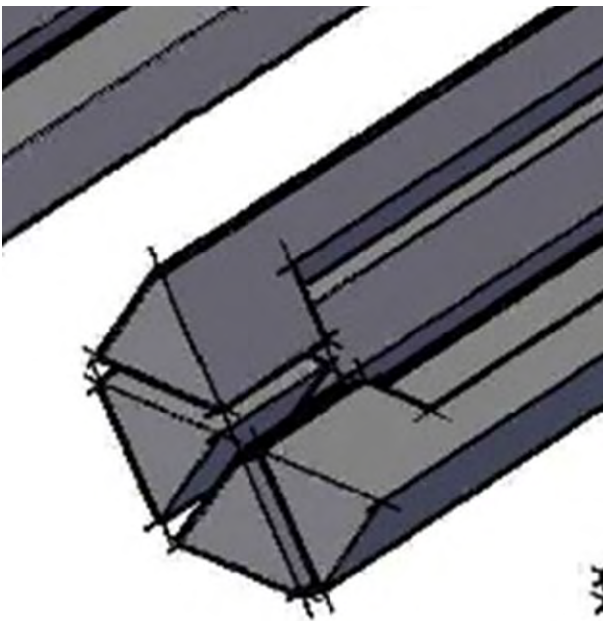

This simplified calculation cannot be applied to the Poratelli hollowing.

In this type of hollowing the solid parts are very close and the section varies continuously from solid to hollow and so on, following the spherical curve of the hollowing.

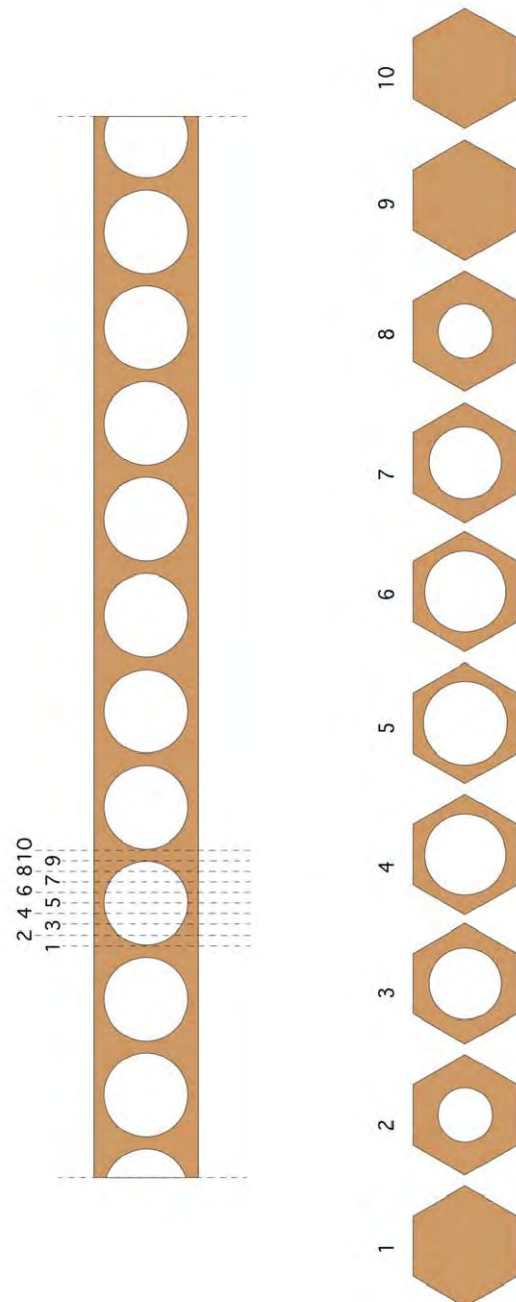

To solve this I acted as follows.

Using a very refined solid modeling software called -“Solidworks” – I made a model of a solid hexagonal rod with a flat to flat diameter of 10 mm and a length of 1 meter. I then made another model which was also hexagonal with the same measurements but hollowed following the Poratelli method.



The rods are fixed at the base and are free at the other end in the classical “shelf” configuration.

Applying the same load (10N) to the tip, the programme shows how the rods deform. Obviously they deform in a different way since one is hollow and the other is solid.

In particular the solid hexagonal one has a displacement of 81,50 mm , while the hollow one has 135,86 mm.

I then found the diameter of the hollow one that would have the same displacement as the original solid one.

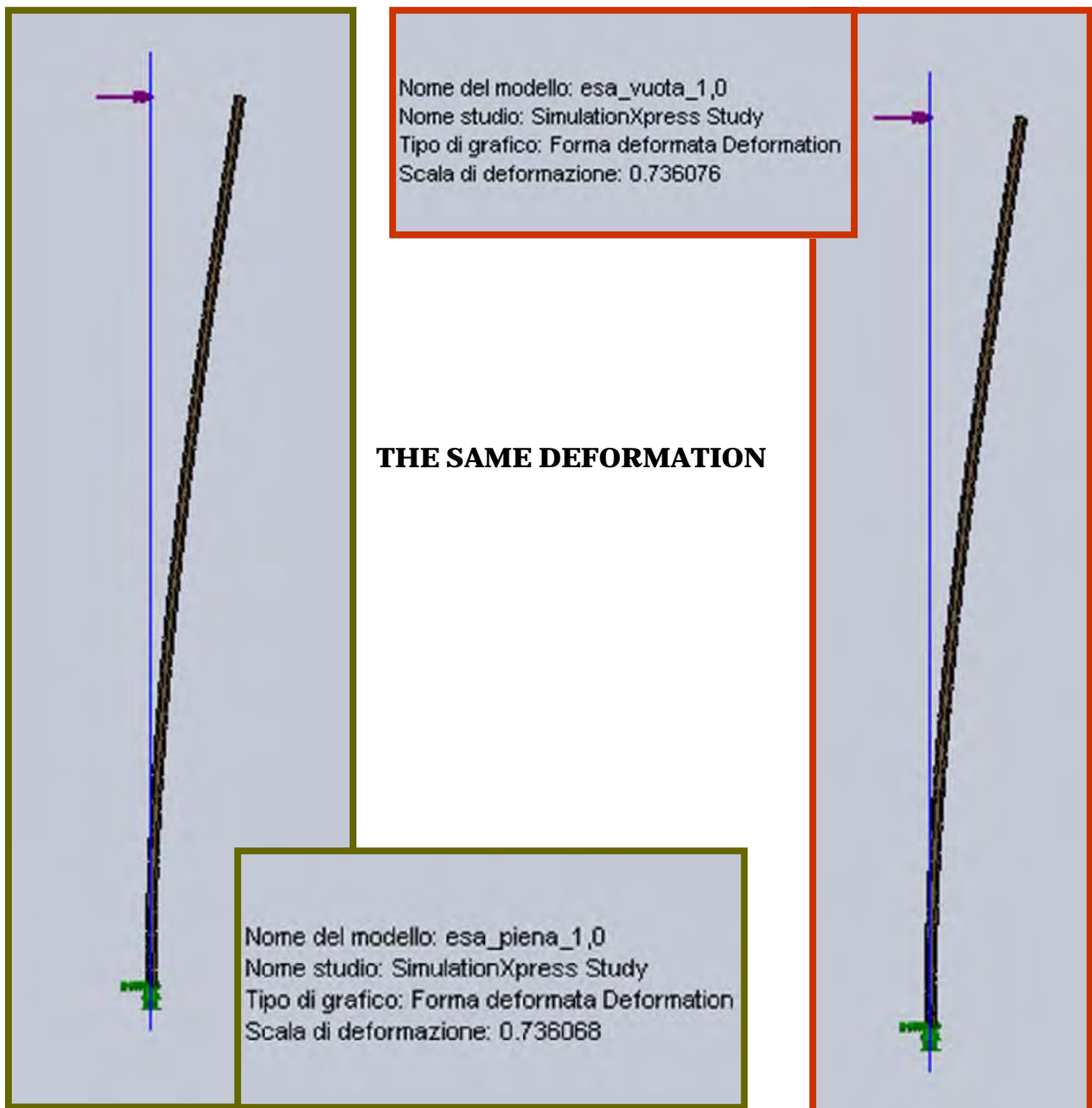

In the case of the hollow hexagonal one with 1 mm walls, the result is 10,327 mm.

Then the volume of the bamboo both in the original solid section as in the hollow section was calculated.

We now have the coefficients of rigidity, of weight to pass from a solid to a Poratelli hollowing.



*The process was repeated  
for the quad ...*



*... for the Penta  
and the Octa*

Finally I managed to update the Table Confronting Sections that today has together with the fluted, the scalloped, the magic star also the new Poratelli Method. This allows you to pass from one section / another free and to evaluate the efficiency.

I hope this can be of help.

Gabriele Gori

**CONFRONTO TRA SEZIONI AVENTI UGUALE MOMENTO D'INERZIA**  
**COMPARISON BETWEEN SECTIONS THAT HAVE THE SAME MOMENT OF INERTIA**

A= area della sezione / cross-section area  
Ixx = momento d'inerzia della sezione / cross-section moment of inertia  
Cxx = distanza dall'asse neutro / distance from the neutral axis  
Wxx = modulo di resistenza della sezione / cross-section modulus

CONFESSIONE / CONSTRUCTION	QUADRATA / QUAD	PENTAGONALE / PENTA	ESAGONALE / HEX	EPTAGONALE PIENA / EPTA	OTTAGONALE / OCTA	DIAMANTE / DIAMOND
<b>PIENA / SOLID</b>	Area: 100,00 mm <sup>2</sup> 2 Ixx: 833,33 mm <sup>4</sup> Cxx: 5,00 mm Wxx: 166,67 mm <sup>3</sup>	Area: 101,48 mm <sup>2</sup> 2 Ixx: 833,39 mm <sup>4</sup> Cxx1: 6,53 mm Cxx2: 5,29 mm Wxx1: 127,59 mm <sup>3</sup> Wxx2: 157,54 mm <sup>3</sup>	Area: 101,94 mm <sup>2</sup> 2 Ixx: 833,27 mm <sup>4</sup> Cxx: 5,42 mm Wxx: 153,61 mm <sup>3</sup>	Area: 102,13 mm <sup>2</sup> 2 Ixx: 833,32 mm <sup>4</sup> Cxx1: 6,11 mm Cxx2: 5,19 mm Wxx1: 136,40 mm <sup>3</sup> Wxx2: 151,23 mm <sup>3</sup>	Area: 102,21 mm <sup>2</sup> 2 Ixx: 833,29 mm <sup>4</sup> Cxx: 5,55 mm Wxx: 150,04 mm <sup>3</sup>	Area: 100,47 mm <sup>2</sup> 2 Ixx: 833,33 mm <sup>4</sup> Cxx1: 6,10 mm Cxx2: 4,88 mm Wxx: 136,66 mm <sup>3</sup> Wxx2: 170,76 mm <sup>3</sup>
<b>SEMPIENA / SEMISOLID</b>						Area: 93,058 mm <sup>2</sup> 2 Ixx: 833,47 mm <sup>4</sup> Cxx1: 6,13 mm Cxx2: 4,89 mm Wxx1: 136,44 mm <sup>3</sup> Wxx2: 170,44 mm <sup>3</sup>
<b>CAVA / HOLLOW</b> spessore parete 2 mm wall thickness 2mm	Area: 67,13 mm <sup>2</sup> Ixx: 833,40 mm <sup>4</sup> Cxx: 5,20 mm Wxx: 160,33 mm <sup>3</sup>	Area: 65,90 mm <sup>2</sup> 2 Ixx: 833,38 mm <sup>4</sup> Cxx1: 6,83 mm Cxx2: 5,53 mm Wxx1: 119,66 mm <sup>3</sup> Wxx2: 150,69 mm <sup>3</sup>	Area: 65,07 mm <sup>2</sup> 2 Ixx: 833,21 mm <sup>4</sup> Cxx: 5,20 mm Wxx: 146,24 mm <sup>3</sup>	Area: 64,58 mm <sup>2</sup> 2 Ixx: 833,24 mm <sup>4</sup> Cxx1: 6,43 mm Cxx2: 5,29 mm Wxx1: 129,50 mm <sup>3</sup> Wxx2: 143,91 mm <sup>3</sup>	Area: 64,29 mm <sup>2</sup> 2 Ixx: 833,34 mm <sup>4</sup> Cxx: 5,28 mm Wxx: 142,47 mm <sup>3</sup>	Area: 65,79 mm <sup>2</sup> 2 Ixx: 833,60 mm <sup>4</sup> Cxx1: 6,39 mm Cxx2: 5,11 mm Wxx1: 130,53 mm <sup>3</sup> Wxx2: 163,13 mm <sup>3</sup>
<b>CAVA / HOLLOW</b> spessore parete 1,5 mm wall thickness 1,5mm	Area: 55,98 mm <sup>2</sup> 2 Ixx: 833,36 mm <sup>4</sup> Cxx: 5,42 mm Wxx: 153,88 mm <sup>3</sup>	Area: 54,81 mm <sup>2</sup> 2 Ixx: 833,39 mm <sup>4</sup> Cxx1: 7,14 mm Cxx2: 5,5 mm Wxx1: 119,80 mm <sup>3</sup> Wxx2: 144,18 mm <sup>3</sup>	Area: 54,14 mm <sup>2</sup> 2 Ixx: 833,32 mm <sup>4</sup> Cxx: 5,36 mm Wxx: 139,77 mm <sup>3</sup>	Area: 53,73 mm <sup>2</sup> 2 Ixx: 833,26 mm <sup>4</sup> Cxx1: 6,79 mm Cxx2: 6,06 mm Wxx1: 129,89 mm <sup>3</sup> Wxx2: 178,51 mm <sup>3</sup>	Area: 53,47 mm <sup>2</sup> 2 Ixx: 833,33 mm <sup>4</sup> Cxx: 6,13 mm Wxx: 135,99 mm <sup>3</sup>	Area: 54,69 mm <sup>2</sup> Ixx: 833,47 mm <sup>4</sup> Cxx1: 6,68 mm Cxx2: 5,34 mm Wxx1: 124,78 mm <sup>3</sup> Wxx2: 156,07 mm <sup>3</sup>
<b>SCANALATA / FLUTED</b> spessore parete 1,5 mm wall thickness 1,5mm	Area: 72,07 mm <sup>2</sup> 2 Ixx: 833,36 mm <sup>4</sup> Cxx: 5,13 mm Wxx: 162,39 mm <sup>3</sup>	Area: 67,85 mm <sup>2</sup> 2 Ixx: 833,43 mm <sup>4</sup> Cxx1: 8,81 mm Cxx2: 5,5 mm Wxx1: 122,48 mm <sup>3</sup> Wxx2: 153,53 mm <sup>3</sup>	Area: 65,16 mm <sup>2</sup> 2 Ixx: 833,44 mm <sup>4</sup> Cxx: 5,20 mm Wxx: 146,25 mm <sup>3</sup>	Area: 62,36 mm <sup>2</sup> 2 Ixx: 833,35 mm <sup>4</sup> Cxx1: 6,48 mm Cxx2: 5,84 mm Wxx1: 126,35 mm <sup>3</sup> Wxx2: 142,79 mm <sup>3</sup>	Area: 60,42 mm <sup>2</sup> 2 Ixx: 833,30 mm <sup>4</sup> Cxx: 5,54 mm Wxx: 140,35 mm <sup>3</sup>	
<b>SCANALATA / FLUTED</b> spessore parete 1 mm wall thickness 1 mm	Area: 72,07 mm <sup>2</sup> 2 Ixx: 833,36 mm <sup>4</sup> Cxx: 5,13 mm Wxx: 159,89 mm <sup>3</sup>	Area: 61,42 mm <sup>2</sup> 2 Ixx: 833,35 mm <sup>4</sup> Cxx1: 6,96 mm Cxx2: 5,83 mm Wxx1: 119,80 mm <sup>3</sup> Wxx2: 148,0 mm <sup>3</sup>	Area: 57,54 mm <sup>2</sup> 2 Ixx: 833,21 mm <sup>4</sup> Cxx: 5,28 mm Wxx: 141,75 mm <sup>3</sup>	Area: 54,46 mm <sup>2</sup> 2 Ixx: 833,32 mm <sup>4</sup> Cxx1: 6,29 mm Cxx2: 6,05 mm Wxx1: 123,97 mm <sup>3</sup> Wxx2: 187,52 mm <sup>3</sup>	Area: 52,04 mm <sup>2</sup> 2 Ixx: 833,33 mm <sup>4</sup> Cxx: 6,72 mm Wxx: 134,62 mm <sup>3</sup>	Area: 70,97 Ixx: 833,25 mm <sup>4</sup> Cxx1: 6,29 mm Cxx2: 5,14 mm Wxx1: 152,51 mm <sup>3</sup> Wxx2: 165,65 mm <sup>3</sup> wall thickness 1 mm
<b>MAGIC STAR / MAGIC STAR</b> spessore parete 2 mm wall thickness 2 mm	Area: 74,16 mm <sup>2</sup> Ixx: 833,39 mm <sup>4</sup> Cxx: 5,27 mm Wxx: 158,10 mm <sup>3</sup>	Area: 82,92 mm <sup>2</sup> Ixx: 833,56 mm <sup>4</sup> Cxx1: 6,74 mm Cxx2: 5,45 mm Wxx1: 123,73 mm <sup>3</sup> Wxx2: 152,54 mm <sup>3</sup>	Area: 80,70 mm <sup>2</sup> 2 Ixx: 833,66 mm <sup>4</sup> Cxx: 5,57 mm Wxx: 149,67 mm <sup>3</sup>	Area: 87,26 mm <sup>2</sup> Ixx: 833,31 mm <sup>4</sup> Cxx1: 6,28 mm Cxx2: 5,86 mm Wxx1: 132,55 mm <sup>3</sup> Wxx2: 147,39 mm <sup>3</sup>	Area: 90,45 mm <sup>2</sup> Ixx: 833,74 mm <sup>4</sup> Cxx: 5,69 mm Wxx: 146,52 mm <sup>3</sup>	
<b>MAGIC STAR / MAGIC STAR</b> spessore parete 1,5 mm wall thickness 1,5 mm	Area: 71,89 mm <sup>2</sup> Ixx: 833,18 mm <sup>4</sup> Cxx: 5,33 mm Wxx: 156,43 mm <sup>3</sup>	Area: 75,90 mm <sup>2</sup> Ixx: 833,32 mm <sup>4</sup> Cxx1: 6,95 mm Cxx2: 5,82 mm Wxx1: 119,95 mm <sup>3</sup> Wxx2: 148,29 mm <sup>3</sup>	Area: 83,50 mm <sup>2</sup> 2 Ixx: 833,38 mm <sup>4</sup> Cxx: 5,71 mm Wxx: 148,98 mm <sup>3</sup>	Area: 81,92 mm <sup>2</sup> Ixx: 833,62 mm <sup>4</sup> Cxx1: 6,45 mm Cxx2: 5,81 mm Wxx1: 129,21 mm <sup>3</sup> Wxx2: 148,98 mm <sup>3</sup>	Area: 85,04 mm <sup>2</sup> Ixx: 833,30 mm <sup>4</sup> Cxx: 5,93 mm Wxx: 143,00 mm <sup>3</sup>	
<b>MAGIC STAR / MAGIC STAR</b> spessore parete 1 mm wall thickness 1 mm	Area: 63,34 mm <sup>2</sup> Ixx: 833,14 mm <sup>4</sup> Cxx: 5,48 mm Wxx: 146,80 mm <sup>3</sup>	Area: 63,89 mm <sup>2</sup> Ixx: 833,07 mm <sup>4</sup> Cxx1: 7,49 mm Cxx2: 7,06 mm Wxx1: 112,06 mm <sup>3</sup> Wxx2: 137,86 mm <sup>3</sup>	Area: 67,30 mm <sup>2</sup> 2 Ixx: 833,32 mm <sup>4</sup> Cxx: 6,14 mm Wxx: 135,66 mm <sup>3</sup>	Area: 70,51 mm <sup>2</sup> Ixx: 833,30 mm <sup>4</sup> Cxx1: 6,87 mm Cxx2: 6,19 mm Wxx1: 121,25 mm <sup>3</sup> Wxx2: 134,62 mm <sup>3</sup>	Area: 74,16 mm <sup>2</sup> Ixx: 833,36 mm <sup>4</sup> Cxx: 6,18 mm Wxx: 134,92 mm <sup>3</sup>	
<b>CAVA AP / HOLLOW AP</b> spessore parete 1,3 mm wall thickness 1,3 mm	Area: 81,94 mm <sup>2</sup> 2 Ixx: 833,33 mm <sup>4</sup>	Area: 84,31 mm <sup>2</sup> 2 Ixx: 833,39 mm <sup>4</sup>	Area: 81,46 mm <sup>2</sup> 2 Ixx: 833,27 mm <sup>4</sup>	Area: 82,37 mm <sup>2</sup> 2 Ixx: 833,32 mm <sup>4</sup>	Area: 80,96 mm <sup>2</sup> 2 Ixx: 833,29 mm <sup>4</sup>	
<b>CAVA AP / HOLLOW AP</b> spessore parete 1 mm wall thickness 1 mm	Area: 74,9194 mm <sup>2</sup> 2 Ixx: 833,33 mm <sup>4</sup>	Area: 76,36 mm <sup>2</sup> 2 Ixx: 833,33 mm <sup>4</sup>	Area: 75,41 mm <sup>2</sup> 2 Ixx: 833,27 mm <sup>4</sup>	Area: 74,00 mm <sup>2</sup> 2 Ixx: 833,32 mm <sup>4</sup>	Area: 72,29 mm <sup>2</sup> 2 Ixx: 833,29 mm <sup>4</sup>	

**4<sup>th</sup> EUROPEAN BAMBOO RODMAKERS GATHERING**  
 Sansaspoleto 6-7-8 Maggio 2011  
  
  
**IBRA**  
 ITALIAN BAMBOO RODMAKERS ASSOCIATION

To download the comparison table between various sections with the same moment of inertia

<http://www.rodmakers.eu/Allegati/calcolo-conversione.xlsx>





Food for thought:

# WATERLOG MAGAZINE

**T**o begin talking about Waterlog Magazine, we need to begin from the house that publishes it: Medlar Press.

Medlar Press was founded by Jon and Rosie Ward-Allen in 1994 in London in a very difficult moment for fishing literature and not only in Great Britain.

It was with difficulty to bring quality fishing books from classical and new authors to interested readers.

All publishing was concentrated essentially on big numbers and this brought it to extreme outsourcing of book publishing.

In that moment, the Wards took a gamble on the possibility to create quality publishing that would attract readers that were more aware of the content than new and passing fashions. Today in 2011, 17 years from its establishment, looking at the catalogue of the books they have published, we must admit that the bet was won successfully. In 1996 Medlar Press decided to start a magazine that would make even more sense in the cultural and editorial ideas of the publisher and Waterlog Magazine was born.

I only discovered Waterlog a few years ago and in quite a strange way: in 2008 I purchased a DVD of a beautiful film/documentary – which by the way I suggest you all watch – The Lost Word of Mr. Hardy by Andy Heathcote.

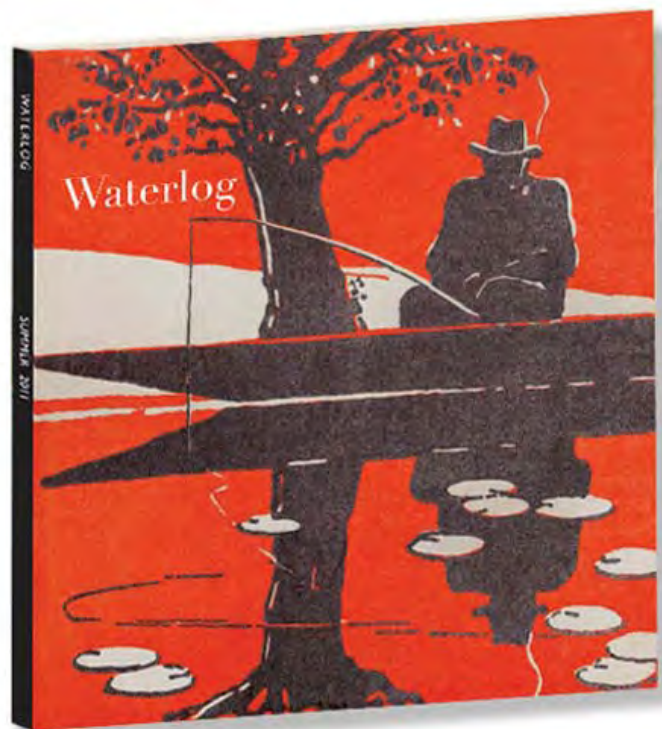

Among the people who appear in the film, is a passionate speech by Jon Ward-Allen, who is introduced as Publisher of Waterlog Magazine. I found his ideas very valid and interesting and I decided to get to know his magazine a little better. I therefore subscribed for one year, then two and then three.....

Waterlog Magazine is about fishing, all fishing. Naturally fly fishing is also present.

If in a magazine you are interested in the news from the market, the last rod made from nanotubes reinforced with colloidal titanium, or the last rod with the drag controlled by microprocessors powered by step by step induction motor, then waterlog is not for you.

If instead you want a magazine in which the intelligence, the culture and the traditions of fishing are important themes in your readings, then you have found your magazine.

The articles are written by people who know how to write, that have ideas and that feel that fishing is not just another way to drag fish out of the water; the long list of collaborators demonstrates this.

I was delighted reading the Summer edition in which Brent Condon described a friendly meeting between a fisherman and a mink on an English lake; of the reciprocal curiosity, interest and the conviviality sealed by the sharing of a couple of sandwiches.

Or of the considerations, the sensation expressed by Dr. Mark Everard in day of fishing that comes to an end and that shows all its moving magic as night falls.

The format is unusual and refined and the printing is excellent: instead of the normal rectangular format, this publication is almost square, 21.30 x 23, printed on heavy paper and is less than 100 pages long.

The photos and drawing that accompany the articles are beautiful. Very little and non invasive publicity.

The covers are another story: refined, elegant – in one word – splendid. The photos and drawings and the graphics are particularly beautiful.

I would suggest to the publishers that they collect and bind the covers – there have been 76 issues – in a portfolio for those who would like to collect and perhaps frame them. I think that many would like this since many issues are sold out.

On the whole, Waterlog is the fruit of an excellent job by Jon Ward-Allen, Editor, by Andrew Herd, Executive Editor and by Rosalind Ward-Allen, Editing Director.

An excellent and unique job in the fishing magazine world.

The magazine comes out quarterly, one for every change of season.

The subscription costs £46 for Europe and £54 for the rest of the world and can be done online:

[http://  
www.medlarpress.com/7982-  
Waterlog-SUBSCRIPTION-  
new-by-The-Worlds-Finest-  
Angling-Magazine.htm](http://www.medlarpress.com/7982-Waterlog-SUBSCRIPTION-new-by-The-Worlds-Finest-Angling-Magazine.htm)



*The Bookworm*



## *Simone Repetti*

*Born in Viareggio in 1965*

I started fishing when I was 10 and other than fishing my great passion is photography.

Lately I dedicate my time looking for details, observing and photographing aquatic environments and the insects we imitate.



<http://www.blogger.com/profile/14129810719428355566>

**BAMBOO JOURNAL**

Newsletter

Of the Italian Bamboo  
Rodmakers Association

c/o Podere Violino  
Località Gricignano  
Sansepolcro (AR)

Italy

[www.rodmakers.it](http://www.rodmakers.it)

[ibra@rodmakers.it](mailto:ibra@rodmakers.it)

§

Editor  
Bamboo Journal

[www.rodmakers.eu](http://www.rodmakers.eu)

[editor@rodmakers.it](mailto:editor@rodmakers.it)



n. 7 year 2011



*In memory of Francesco Amico*